

THE COUPLING.



INDUSTRIAL COUPLINGS

R+W is one thing above all: **THE COUPLING.**

The company **Who we are**

Day after day, we at R+W make the impossible possible and drive technology for tomorrow. Our couplings are usually only a small component of larger solutions - but they are a decisive factor when it comes to moving components.

Close by worldwide

From our headquarters in Wörth am Main, Germany, we operate as a global industrial enterprise and maintain subsidiaries and sales offices in Italy, France, Slovakia, the USA, China and Singapore.

We attach great importance to close cooperation with our customers and partners. Our goal is to provide our customers with outstanding technical advice and individual development services. That is why we promote our strong and extensive network of more than 80 premium partners and are represented worldwide in over 65 countries close to the market.

Since our founding in 1990, we have developed into the technology leader with in-depth coupling know-how. From batch size 1 we tackle new projects together and implement them consistently.

We produce and deliver more than 1,000,000 couplings annually around the world, from our production facilities in Germany, Slovakia and the USA.



Sustainable Principles

Ecological. Social. Economic. Sustainable development is only possible if we give equal weight to economic growth, social security and ecological compatibility on an equal footing. Our sustainability initiatives take this into account. They span all areas of the company and provide a comprehensive and reliable framework for responsible use of resources.



Natural progress

We are striving to gradually move closer to our goal of zero emissions. To this end, we constantly monitor our consumption levels and rely on technologies and equipment with high resource efficiency. Green energy for our production is provided by a 180-kWp photovoltaic system. The purchased energy comes 100% from hydropower. We reduce process water through targeted fine filtration and cascading.

Social plus

Here, the focus is on those who are the plus at R+W: our employees. We place occupational health and safety at the top of our agenda, and provide continuous investment in this area. A high level of process reliability guarantees the high quality of our couplings and ensures the benefit for our customers.

Long-term value

For success to be sustainable, we must think economically. The prerequisite for this is a modern infrastructure, continuous process improvement in the value chain and cooperation with sustainable suppliers and service providers.



Implementation How we succeed with Forward thinking



Smart future here today!

With the Intelligent Coupling from R+W Antriebselemente, we are setting a sign for modern developments in the course of digitalization, automation and the Industrial Internet of Things (IIoT).

As a technology leader and specialist, we recognized this early on: The transformation to networked Industry 4.0 cannot be avoided. Data and its efficient use are becoming increasingly valuable. We do not want to simply but to actively help shape it for our customers and turn it into reality.

In drive technology, real-time data acquisition has been a major challenge. The reason: a rotating drive axis cannot be easily connected to a cable – until now! Thanks to the Intelligent Coupling from R+W, this situation has changed fundamentally.

R+W Milestones

1993



Development of the first plug-in metal bellows coupling on the market

New technical standards and superior competitive advantage in elastomer couplings



1999

2001-
2004



International openings:
USA (sales office), Slovakia (component production) and China (sales office)

New standard for TÜV tested safety couplings + development of a special safety coupling for the International Space Station



2006

**More
R+W Couplings**

For further information and products please refer to our catalogs of precision and/or industrial couplings.

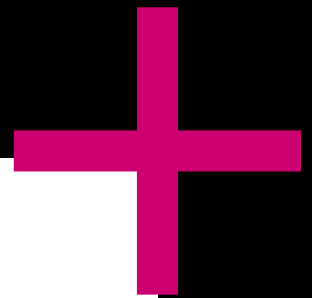

The new generation of coupling: Intelligent couplings with built-in sensor technology



2008



Additional site opening in Italy

2020

2023



Sales office in Chicago becomes a full production facility

Industrial couplings

200 – 40,000,000 Nm

Model	Features	Page
ST	TORQSET® Safety couplings 200-40,000,000 Nm <ul style="list-style-type: none">• Compact, simple design• Precise overload protection• Adjustable disengagement torque• Robust• Full disengagement up on overload	16
LP	High strength disc pack coupling 350 – 50,000 Nm <ul style="list-style-type: none">• Maintenance free for infinite life• Frictional clamping of disc packs• High speeds with extended DBSE• Zero backlash• High torsional stiffness• Low restoring forces from misalignment	40
BZ	Flexible gear couplings 1,900 – 2,080,000 Nm <ul style="list-style-type: none">• Very compact design• Corrosion resistant• Large misalignment compensation• Reduced wear design• Low maintenance	58

Model	Features	Page
<div style="border: 1px solid black; padding: 2px; display: inline-block;">BX</div>	<p>Torsionally stiff bellows couplings 10,000 – 100,000 Nm</p> <ul style="list-style-type: none"> • Robust construction • High torsional stiffness • Fatigue resistant for infinite life • Easy to mount and dismount • Precise rotational transmission • Minimal restoring loads under misalignment 	66
<div style="border: 1px solid black; padding: 2px; display: inline-block;">ATEX</div>	<p>For use in hazardous environments For hazardous zones 1/21 and 2/22 these couplings are authorized under directive 94/9/EG.</p> <ul style="list-style-type: none"> • Safety couplings • Bellows couplings • Disc pack couplings 	72

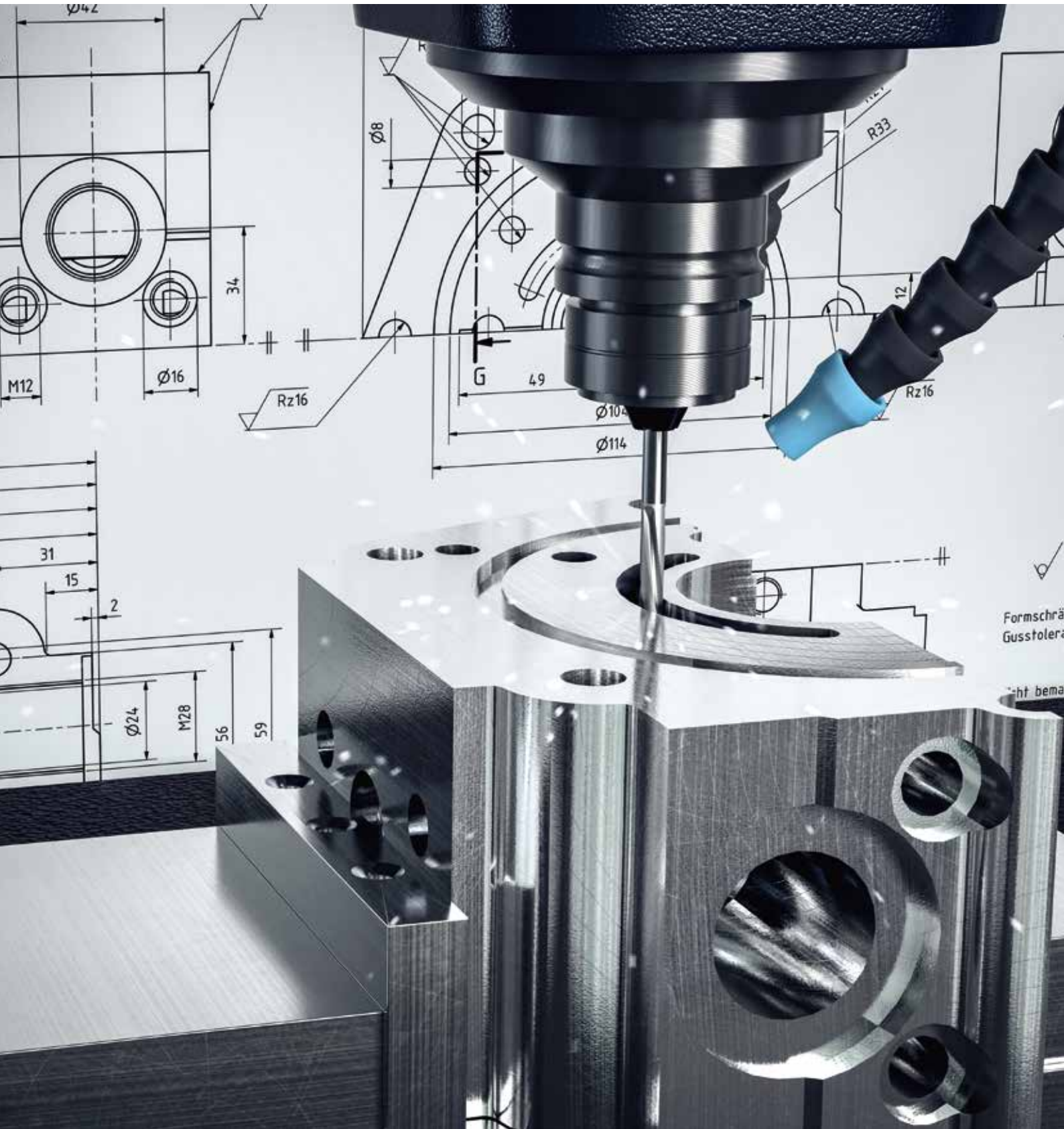

Sizing and selection



Proper sizing of couplings is crucial to ensuring smooth and efficient power transmission. This involves taking the specific requirements and operating conditions of the application into account. Various factors such as torque, speed, temperature and shock loads must be considered when selecting the correct coupling type and size.

According to DIN 740 part 2

Legend guide book industrial couplings

T_{AR}	=	Disengagement torque of the coupling (Nm)
K	=	Service factor
T_{max}	=	Maximum torque of the drive system (Nm)
T_{AN}	=	Rated torque of the motor (Nm)
P_{Drive}	=	Drive power (kW)
n	=	Drive speed (min^{-1})
α	=	Angular acceleration (rad/s^2)
t	=	Acceleration time (s)
ω	=	Angular velocity (rad/s)
J_L	=	Moment of inertia of load (kgm^2)
J_A	=	Moment of inertia of drive (kgm^2)
T_{AS}	=	Peak motor torque (Nm)
S	=	Number of safety elements
F	=	Tangential force (kN)
r	=	Radius to element (m)
s	=	Spindle pitch (mm)
F_V	=	Feed force (N)
η	=	Spindle efficiency
d_0	=	Pitch diameter (mm)
C_T	=	Torsional stiffness of coupling (Nm/rad)
J_{Masch}	=	Total load inertia (kgm^2) (e.g. shaft + sprocket + chain + roller + 1/2 of coupling)
$J_{Mot.}$	=	Total driving inertia (kgm^2) (e.g. motor shaft + 1/2 of coupling)
f_e	=	Resonant frequency of the two mass system (Hz)
f_{er}	=	Excitation frequency of the drive (Hz)
T_{KN}	=	Rated torque of coupling (Nm)
T_{AS}	=	Peak torque (Nm) e.g. maximum acceleration peak torque or maximum braking torque from the load
φ	=	Angle of twist (degree)
S_A	=	Load factor
N	=	Length to flexure (mm)

Sizing and selection

Formulas

Shock / load factor S_A

uniform load	non-uniform load	heavy shock load
1	2	3

For many crushing and shredding applications load factors are commonly $S_A = 2-3$

According to disengagement torque

Safety couplings are normally selected according to the required disengagement torque, which must be greater than the maximum torque required for start-up and operation.

Disengagement torque values are often determined from the drive data and are typically a multiple of the nominal torque at the operating drive speed (TAN). In addition to a start-up torque (Tmax.), the following values are used as further safety factors, depending on the load conditions:

- K = 1.3 uniform harmonious load
- K = 1.5 non-uniform load
- K = 1.8 heavy shock load

$$T_{AR} \geq K \cdot T_{max} \text{ (Nm)}$$

or

$$T_{AN} \geq 9,550 \cdot \frac{P_{Drive}}{n} \text{ (Nm)}$$

According to torque

1. Calculate the drive torque T_{AN} .
2. Base the coupling rated torque T_{KN} on the drive torque T_{AN} multiplied by the application factors.

$$T_{AN} \geq 9,550 \cdot \frac{P_{Drive}}{n} \text{ (Nm)}$$

$$T_{KN} \geq T_{AN} \cdot S_A \cdot S_u \cdot S_Z$$

Couplings are normally sized for the highest torque to be regularly transmitted. The peak torque of the application should not exceed the rated torque of the coupling. The following calculation provides an approximation of the minimum required coupling size, and allows for the maximum rated speed and misalignment to exist in the application.

$$T_{KN} \geq 1.5 \cdot T_{AS} \text{ (Nm)}$$

Formulas

According to acceleration
(Start-up with no load)

$$T_{AR} \geq \alpha \cdot J_L \geq \frac{J_L}{J_A + J_L} \cdot T_{AS} \cdot S_A \text{ (Nm)}$$

$$\alpha = \frac{\omega}{n} = \frac{\pi \cdot n}{t \cdot 30}$$

According to acceleration
(Start-up with load)

$$T_{AR} \geq \alpha \cdot J_L + T_{AN} \geq \left[\frac{J_L}{J_A + J_L} \cdot (T_{AS} - T_{AN}) + T_{AN} \right] \cdot S_A \text{ (Nm)}$$

According to the number
of safety elements

$$T_{AR} = S \cdot F \cdot r$$

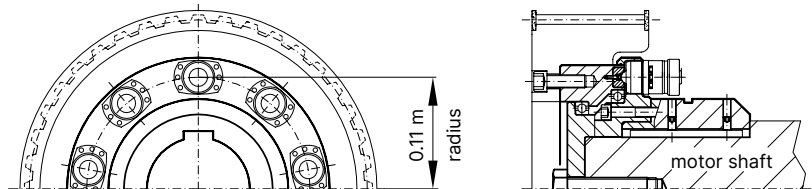

According to linear feed force

Screw drive

$$T_{AN} = \frac{s \cdot F_v}{2,000 \cdot \pi \cdot \eta} \text{ (Nm)}$$

Rack and pinion drive

$$T_{AN} = \frac{d_0 \cdot F_v}{2,000} \text{ (Nm)}$$

Sizing and selection

Formulas

According to resonant frequency

The torsional natural frequency of the coupling must be significantly higher or lower than that of the equipment. For the mechanical substitution model the two mass system applies.

$$f_e = \frac{1}{2 \cdot \pi} \sqrt{C_T \cdot \frac{J_{Masch} + J_{Mot}}{J_{Masch} \cdot J_{Mot}}} \quad (\text{Hz})$$

According to accleration torque

A more detailed calculation takes acceleration and the driving and driven moments of inertia into account. A strong inertia ratio diminishes the effect of the load factor in the sizing calculation.

$$T_{KN} \geq T_{AS} \cdot S_A \cdot \frac{J_L}{J_A + J_L} \quad (\text{Nm})$$

According to torsional deflection

To calculate transmission error as a result of torsional stress:

$$\varphi = \frac{180}{\pi} \cdot \frac{T_{AS}}{C_T} \quad (\text{degree})$$

Sizing and selection

Design disc pack couplings

Taking into account the friction drive principle of the R+W disc coupling design, torque is transferred without micro-movements or backlash.



Misalignment comensation

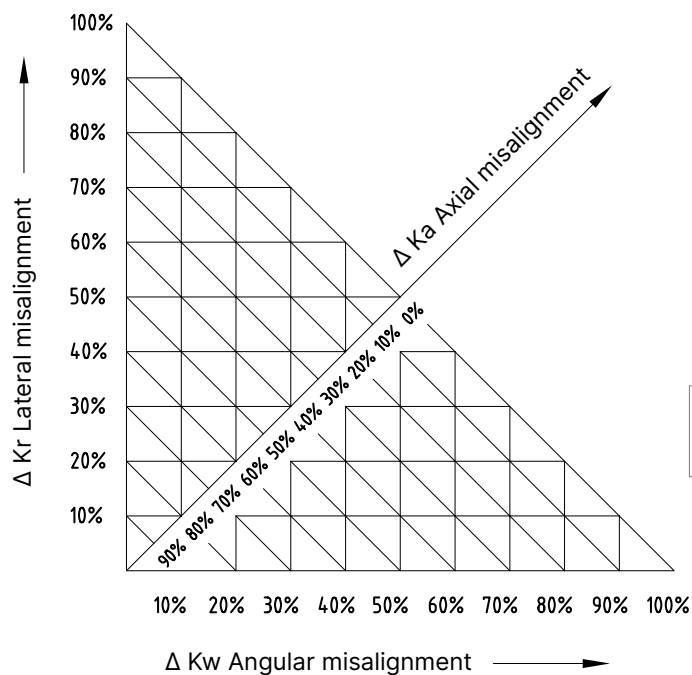

$$\Delta K_{total} = \Delta K_r + \Delta K_w + \Delta K_a \leq 100\%$$

The maximum total misalignment of the disc coupling should not exceed 100% of the combined percentages of the maximum axial, angular and lateral values as shown in the product data tables.

Example: pump skid

axial misalignment: 20%
lateral misalignment: 40%
angular misalignment: 40%

$$\Delta K_{total} = 20\% + 40\% + 40\% \leq 100\%$$

➔ coupling is fatigue resistant





TORQSET® safety couplings

200 – 40,000,000 Nm



Areas of application

- + Timber processing machinery
- + Bulk material handling systems
- + Tunnel boring machinery
- + Industrial shredders
- + Rotary test stands
- + Extruder drives
- + Wastewater scraper drives
- + Wherever potential for torque overload exists

Temperature range
-15°C to +80°C

Fit clearance
Overall shaft / hub clearance of 0.02 - 0.07 mm

Special solutions
Automatic re-engagement

ATEX (Optional)
Available on request

Disengagement behavior
Full disengagement / manual reset is standard

Ordering Example	STR	10	4-10	20	100	XX
Model	●					Special designation only (e.g. special bore diameter tolerances, balancing, etc.). Contact R+W for more information
Size		●				
Adjustment range			●			
Disengagement torque				●		
Bore D1					●	
For custom features place an XX at the end of the part number and describe the special requirements (e.g. STR / 10 / 4-10 / 20 / 100 / XX)						

Safety couplings

Reliable torque overload protection

ST series safety couplings are designed to decouple machine drives in the event of torque overload, preventing damage and downtime.

A series of ball bearings are spring loaded into detents on an otherwise freely spinning output plate. In the case of the ST series, these ball bearings are mounted onto plungers which are individually loaded in order to generate high clutching forces while maintaining a relatively small profile.

The transmittable torque is determined by the number and force setting of the safety elements and

their distance from the center of the rotational axis. In the event of an overload, the force applied by the detents causes the plungers to overcome the spring loading and retract into the housings, resulting in a complete separation of the driving and driven hubs.

They will not re-engage automatically. After the overload condition has passed, an axial force must be applied in order to re-engage the safety elements into the detents of the output plate.

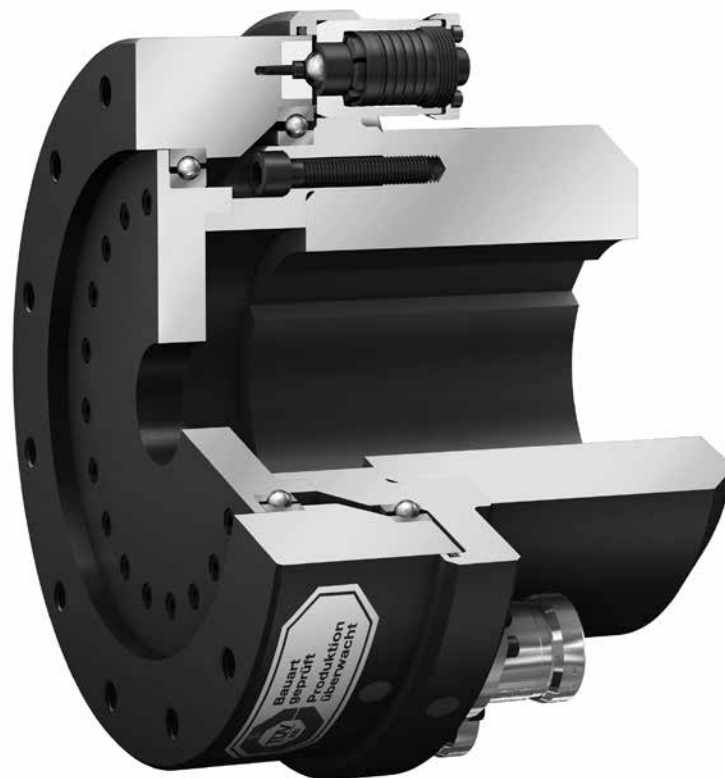

Image: The ST1 safety coupling with integral bearings and hardened races to absorb axial and lateral forces. The ST1 is the basic model of the ST series.

Safety couplings

Serie ST1R - ST5

All coupling variants are designed with a reinforced bearing adapted to the application. This serves to enable high speeds and absorb axial and transverse

loads. Depending on the application and external loading, they are normally angular contact or tapered roller bearings.

Safety element



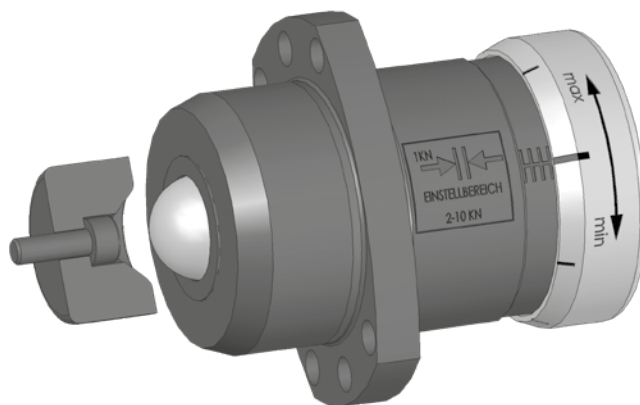

The safety elements consist of two components: the detent receptacle and the adjustable plunger mechanism.





ST

TORQSET® Safety couplings

200 – 40,000,000 Nm

Model		Features	Page
ST1		<p>With simple keyway mounting for indirect drives 200 – 25,000 Nm</p> <ul style="list-style-type: none">• Compact, simple design• Precise overload protection• Torsionally stiff• Integral bearing for overhung load support	22-23
ST1 R		<p>With keyway mounting special robust version 200 – 250,000 Nm</p> <ul style="list-style-type: none">• Compact, simple design• Precise overload protection• Torsionally stiff• With heavy duty bearing for overhung load support	24-25
STN		<p>With conical clamping ring for indirect drives 200 – 165,000 Nm</p> <ul style="list-style-type: none">• High shaft clamping pressure• Compact, simple design• Precise overload protection• Torsionally stiff• With heavy duty bearing for timing belt pulley or sprocket	26-27
STF		<p>With flange mounting both sides 200 – 45,000 Nm</p> <ul style="list-style-type: none">• Compact design with customer specified interface for torque transducers and other mounting flanges• Precise overload protection• Torsionally stiff• With special bearing for high speeds	28

Model	Features	Page
STE	 <p>With keyway mounting and elastomer coupling 200 – 14,000 Nm</p> <ul style="list-style-type: none"> • Vibration damping • Precise overload protection • Wear resistant • Press fit design • With reinforced bearing suitable for extrusion machinery 	29
ST4	 <p>With simple keyway mounting and crowned gear coupling 200 – 250,000 Nm</p> <ul style="list-style-type: none"> • High power density • Compensation for misalignment • Precise overload protection • Low reaction loads on shaft bearings • Extremely wear resistant • With reinforced bearing 	30-31
ST5	 <p>With simple keyway mounting and highly flexible coupling 200 – 19.000 Nm</p> <ul style="list-style-type: none"> • High damping • Compensation for misalignment • Precise torque limitation • Wear resistant • Low backlash • With reinforced bearing 	32-33
ACCESSORIES	Accessories for Safety Couplings	34-38
ST	Options / Special Solutions	39

ST1

With simple keyway mounting

200 – 25,000 Nm



Features

- Compact, simple design
- Precise overload protection
- Torsionally stiff
- Integral bearing for overhung load support

Material

Hardened steel (nitrocarburized surface)

Design

- **Drive side:** coupling hub with keyway connection (spline profile on request)
- **Driven side:** output flange with 12x fastening threads and integral bearings
- **Safety elements:** evenly spaced around the circumference; externally adjustable

Model ST1 | Size 2–5

Size		2			5		
Adjustment range available from - to	(KNm)	0.2-0.5	0.5-1.0	1.0-1.5	0.7-2	1.2-4	3.2-5
		3×ST10	6×ST10	6×ST10	3×ST15	6×ST15	6×ST15
Overall length	(mm)	A ₁	120			150	
Bore depth	(mm)	A ₂	100			124	
Outside diameter	(mm)	B	198			220	
Fit length	(mm)	C	100			121	
Bore diameter possible Ø to Ø F7	(mm)	D	30-75			40-90	
Flange centering diameter H7	(mm)	E	132			145	
Bolt circle diameter ±0,3	(mm)	F	162			170	
Flange outside diameter h7	(mm)	G	192			209	
Fastening threads		H	12xM10			12xM12	
Thread depth	(mm)	I	15			20	
Fit length	(mm)	J	3.5			4	
Wall thickness	(mm)	K	15			21	
Distance	(mm)	L	10.5			16.5	
Distance	(mm)	M	51.5			66.5	
Actuation path	(mm)	N	3.5			4.5	
Mounting diameter - elements	(mm)	O	154			171	
Hub outside diameter	(mm)	P	104			120	
Bore for fastening screw	(mm)	Q	max. Ø 75			max. Ø 90	
Moment of inertia (approx.) D max. + max. sgmnt	(10 ⁻³ kgm ²)		77			151	
Speed max.	(1/min.)		7,000			6,000	
Allowable max. radial force standard*	(KN)		5			10	
Approx. weight at D max. + max. sgmnt	(kg)		15			24	

* larger radial loads possible with special bearings

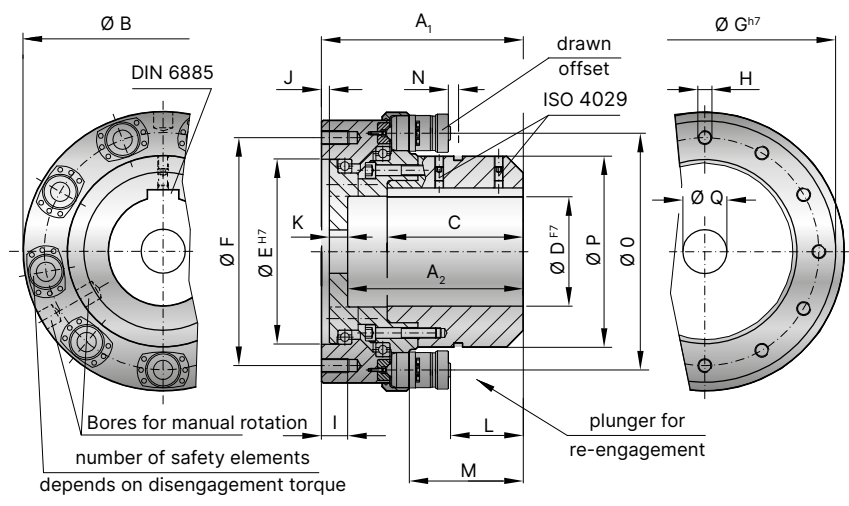

Model ST1 | Size 10-25

Size		10			25			
Adjustment range available from - to	(KNm)		2-5	4-10	6-14	6-12	9-18	15-25
			3×ST15	6×ST15	9×ST15	6×ST15	9×ST15	12×ST15
Overall length	(mm)	A ₁		183			230	
Bore depth	(mm)	A ₂		158			200	
Outside diameter	(mm)	B		270			318	
Fit length	(mm)	C		120			155	
Bore diameter possible Ø to Ø F7	(mm)	D		40-110			60-140	
Flange centering diameter H7	(mm)	E		170			210	
Bolt circle diameter ±0,3	(mm)	F		220			260	
Flange outside diameter h7	(mm)	G		259			298	
Fastening threads		H		12xM16			12xM16	
Thread depth	(mm)	I		25			30	
Fit length	(mm)	J		6			8	
Wall thickness	(mm)	K		17			20	
Distance	(mm)	L		45			80	
Distance	(mm)	M		95			130	
Actuation path	(mm)	N		4			4	
Mounting diameter - elements	(mm)	O		220			270	
Hub outside diameter	(mm)	P		170			218	
Bore for fastening screw	(mm)	Q		max. Ø 110			max. Ø 140	
Moment of inertia (approx.) D max. + max. sgmnt (10 ⁻³ kgm ²)				370			780	
Speed max.	(1/min.)			4,200			3,800	
Allowable max. radial force standard*	(KN)			20			30	
Approx. weight at D max. + max. sgmnt	(kg)			40			63	

* larger radial loads possible with special bearings

ST1 R

With simple keyway mounting, robust

200 – 250,000 Nm



Features

- Compact, simple design
- Precise overload protection
- Torsionally stiff
- With heavy duty bearing for overhung

Material

- Hardened steel (nitrocarburized surface).
- Corrosion resistant surface treatments

Design

- **Drive side:** coupling hub with keyway connection
- **Driven side:** Output flange with attachment threads and reinforced bearings.
- **Safety elements:** The ST safety segments are evenly distributed around the circumference of the coupling. They ensure the safe disconnection of the driveline in the event of overload, and can be adjusted within a fixed range.

Model ST1R | Size 2–40

Size		2				5			10			25			40		
Adjustment range available from - to (KNm)		0.2-0.5	0.5-1.0	1.0-1.5	1.5-3.5	0.7-2	1.2-4	3.2-5	2-5	4-10	6-14	6-12	9-18	15-25	12-21	22-32	32-45
		3x ST11	6x ST11	6x ST11	6x ST11	3x ST16	6x ST16	6x ST16	3x ST16	6x ST16	9x ST16	6x ST16	9x ST16	12x ST16	6x ST31	6x ST31	9x ST31
Overall length (mm)	A _i	170				190			230			264			335		
Outside diameter (mm)	B	198				220			270			318			428		
Fit length Bore depth (mm)	C	85 / 95				100 / 111			122			150			191		
Bore diameter possible Ø to Ø F7 (mm)	D	30-80				40-90			40-110			60-140			90-170		
Flange centering diameter H7 (mm)	E	132				145			170			210			270		
Bolt circle diameter ±0.2 (mm)	F	162				170			220			260			330		
Flange outside diameter h7 (mm)	G	192				209			259			298			380		
Fastening threads	H	12xM10				12xM12			12xM16			12xM16			12xM20		
Thread depth (mm)	I	18				22			28			30			36		
Fit length (mm)	J	4.5				3.5			6			8			6		
Wall thickness (mm)	K	16				24			32			32			48		
Distance (mm)	L	50				56			74			97			111.5		
Distance (mm)	M	81				97			115			138			171		
Actuation path (mm)	N	3.5				4.5			4.5			4.5			7.5		
Mounting diameter - elements (mm)	O	154				171			220			270			350		
Hub outside diameter (mm)	P	112				122			170			218			265		
Bore for fastening screw (mm)	Q	17				25			26			32			38		
Moment of inertia (approx.) D max. + max. sgmnt (10 ⁻³ kgm ²)		103				168			484			1,028			4,107		
Speed max. (1/min.)		8,500				6,300			5,000			4,000			3,600		
Allowable max. radial force standard* (KN)		10				20			40			60			80		
Approx. weight at D max. + max. sgmnt (kg)		21				28			55			86			196		

* larger radial loads possible with special bearings

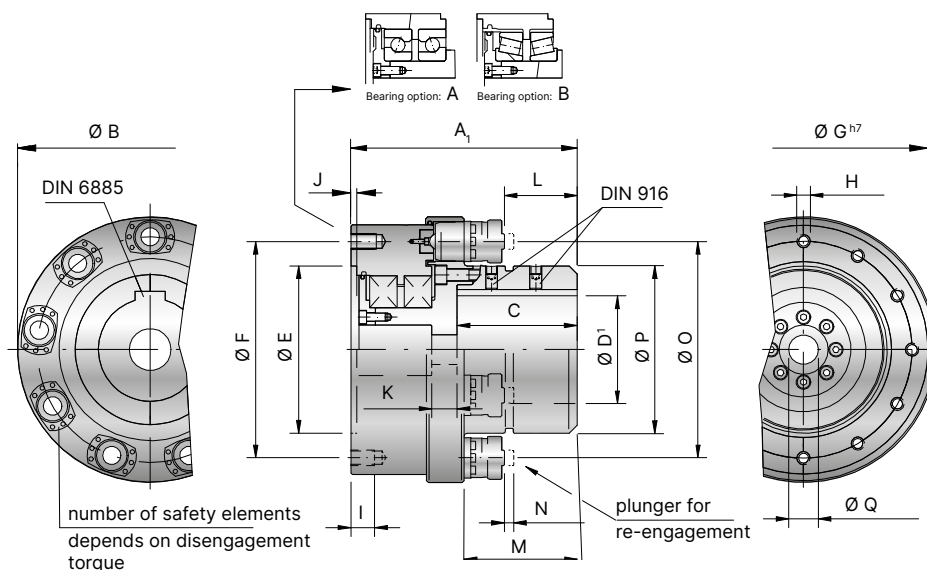

Model ST1R | Size 60 - 250

Size		60			100			160			250	
Adjustment range available from - to (KNm)		11-18	22-36	30-55	24-50	45-90	80-110	25-55	50-110	80-165	100-170	160-250
		3×ST31	6×ST31	9×ST31	3×ST71	6×ST71	9×ST71	3×ST71	6×ST71	9×ST71	8×ST71	12×ST71
Overall length (mm)	A ₁	380			470			490			600	
Outside diameter (mm)	B	459			592			648			740	
Fit length Bore depth (mm)	C	220			275			282			361	
Bore diameter possible Ø to Ø F7 (mm)	D	90-200			100-250			130-290			200-340	
Flange centering diameter H7 (mm)	E	300			390			450			508	
Bolt circle diameter ±0.2 (mm)	F	360			464			570			600	
Flange outside diameter h7 (mm)	G	418			530			618			680	
Fastening threads	H	12xM20			12xM24			12xM24			12xM36	
Thread depth (mm)	I	36			40			44			60	
Fit length (mm)	J	9			10			11			12	
Wall thickness (mm)	K	53.5			67			67			78	
Distance (mm)	L	143			179			189			273	
Distance (mm)	M	202.5			255			265			349	
Actuation path (mm)	N	7.5			10			10			10	
Mounting diameter - elements (mm)	O	376			490			532			630	
Hub outside diameter (mm)	P	295			380			420			508	
Bore for fastening screw (mm)	Q	44			44			52			52	
Moment of inertia (approx.) D max. + max. sgmnt (10 ⁻³ kgm ²)		5,925			20,000			31,830			61,300	
Speed max. (1/min.)		3,200			2,200			2,000			1,800	
Allowable max. radial force standard* (KN)		100			130			200			240	
Approx. weight at D max. + max. sgmnt (kg)		244			502			636			978	

* larger radial loads possible with special bearings

STN

With conical clamping bushing

200 – 5,000 Nm



2,000 – 165,000 Nm



Features

- High shaft clamping pressure
- Compact, simple design
- Precise overload protection
- Torsionally stiff
- With heavy duty bearing for timing belt or chain sprocket

Material

- Hardened steel (nitrocarburized surface).
- Corrosion resistant surface treatments

Design

- **Drive side:** hub with slotted conical bushing
- **Output side:** mounting flange with integral bearing.
Connection via pilot and bolt circle.
- **Safety elements:** The ST safety segments are evenly distributed around the circumference of the coupling. They ensure the safe disconnection of the driveline in the event of overload, and can be adjusted within a fixed range.

Model STN | Size 2-5

Size	2				5		
	0.2-0.5	0.5-1.0	1.0-1.5	1.5-3.5	0.7-2	1.2-4	3.2-5
Adjustment range available from - to	3×ST10	6×ST10	6×ST10	6×ST11	3×ST16	6×ST16	6×ST16
Overall length (mm)	A ₁	170			190		
Flange outside diameter (mm)	B	198			220		
Fit length / keyway length (mm)	C ₁	85			111		
Effective clamping length (mm)	C ₂	33			39		
Bore diameter possible Ø to Ø F7 (mm)	D ₂	35-75			40-96		
Flange centering diameter H7 (mm)	E	132			145		
Bolt circle diameter ±0,3 (mm)	F	162			170		
Outside diameter h7 (mm)	G	192			209		
Fastening threads	H	12×M10			12×M12		
Thread depth (mm)	I	18			22		
Fit length (mm)	J	3.5			3.5		
Tightening screw ISO 4017	K	M10			M12		
Tightening torque (Nm)		59			100		
Distance (mm)	L	50			56		
Distance (mm)	M	81			97		
Actuation path (mm)	N	3.5			4.5		
Mounting diameter - elements (mm)	O	154			171		
Hub outside diameter (mm)	P	135			180		
Moment of inertia (approx.) D max. + max. sgmnt (10 ⁻³ kgm ²)		103			168		
Speed max. (rpm)		8,500			6,300		
Allowable max. radial force standard* (KN)		10			20		
Approx. weight at D max. + max. sgmnt (kg)		21			28		

* larger radial loads possible with special bearings

Size
200 – 5,000 Nm

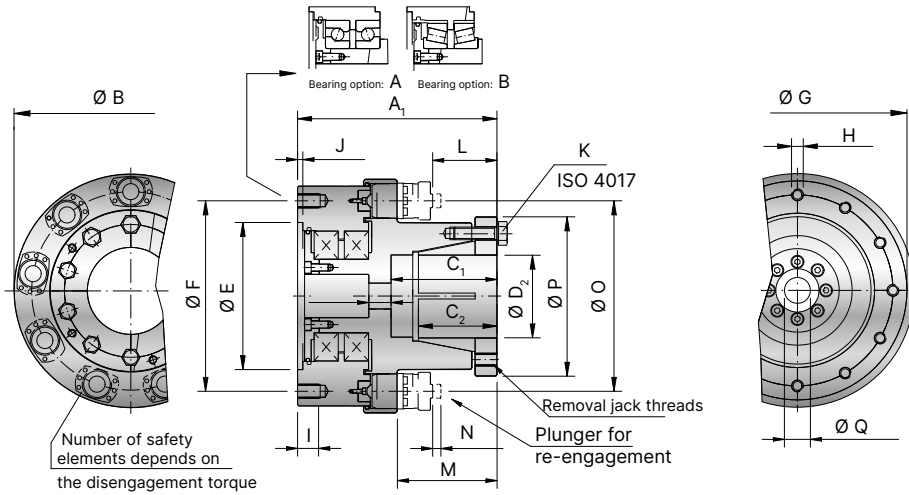

Size
2,000 – 165,000 Nm

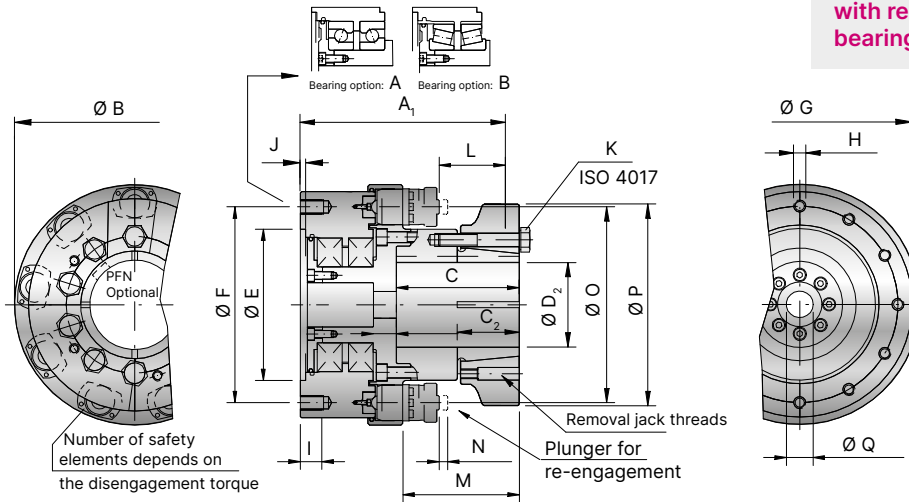

with reinforced bearing

SAFETY COUPLINGS
ST

Model STN | Size 10-160

Size	10			25			40			60			100			160			
	2-5 3x ST16	4-10 6x ST16	6-14 9x ST16	6-12 6x ST16	9-18 9x ST16	15-25 12x ST16	12-21 6x ST31	22-32 6x ST31	32-45 9x ST31	11-18 3x ST31	22-36 6x ST31	30-55 9x ST31	24-50 3x ST71	45-90 6x ST71	80-110 9x ST71	25-55 3x ST71	50-110 6x ST71	80-165 9x ST71	
Adjustment range available from - to																			
Overall length (mm)	A ₁	240			270			330			380			470			500		
Flange outside diameter (mm)	B	270			318			428			459			592			648		
Fit length / keyway length (mm)	C ₁	132			156			186			220			275			292		
Effective clamping length (mm)	C ₂	67			70			82.5			97			100			133		
Bore diameter possible Ø to Ø F7 (mm)	D ₁	65-110			70-150			90-170			80-200			200-250			200-290		
Flange centering diameter H7 (mm)	E	170			210			270			300			390			450		
Bolt circle diameter ±0,3 (mm)	F	220			260			330			360			464			570		
Outside diameter h7 (mm)	G	259			298			380			418			530			618		
Fastening threads	H	12xM16			12xM16			12xM20			12xM20			12xM24			12xM24		
Thread depth (mm)	I	28			30			36			36			40			44		
Fit length (mm)	J	6			8			6			9			10			11		
Tightening screw ISO 4017	K	M16			M16			M16			M20			M24			M24		
Tightening torque (Nm)	K	180			180			300			570			680			680		
Distance (mm)	L	84			103			106.5			143			179			199		
Distance (mm)	M	125			144			166			202.5			255			275		
Actuation path (mm)	N	4.5			4.5			7.5			7.5			10			10		
Mounting diameter - elements (mm)	O	220			270			350			376			490			532		
Hub outside diameter (mm)	P	218			218			322			380			470			538		
Moment of inertia (approx.) D max. + max. sgmnt (10 ⁻³ kgm ²)		440			780			3,570			4,600			XXX			XXX		
Speed max. (rpm)		5,000			4,000			3,600			3,200			2,200			2,000		
Allowable max. radial force standard* (kN)		40			60			80			100			130			200		
Approx. weight at D max. + max. sgmnt (kg)		50			63			166			179			XXX			XXX		

* larger radial loads possible with special bearings

STF

With flange mounting

200 – 45,000 Nm



Features

- Compact design with customer specified interface for torque transducers and other mounting flanges
- Precise overload protection
- Torsionally stiff
- With special bearing for high speeds

Material

- Hardened steel (nitrocarburized surface)
- Corrosion resistant surface treatments

Design

- **Drive side:** mounting flange with pilot and bolt circle.
- **Output side:** mounting flange with integral bearing. Connection via pilot and bolt circle.
- **Safety elements:** The ST safety segments are evenly distributed around the circumference of the coupling. They ensure the safe disconnection of the driveline in the event of overload, and can be adjusted within a fixed range.

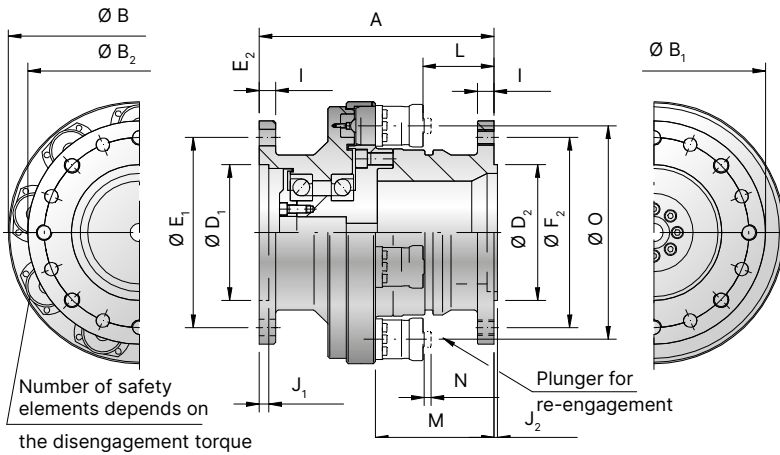

with reinforced bearing

Model STF | Size 2-40

Higher torque on request

Size	2			5			10			25			40			
	0.2-0.5	0.5-1.0	1.0-1.5	1.5-3.5	0.7-2	1.2-4	3.2-5	2-5	4-10	6-14	6-12	9-18	15-25	12-21	22-32	32-45
Adjustment range available from to (KNm)	3×ST10	6×ST10	6×ST10	6×ST10	3×ST15	6×ST15	6×ST15	3×ST15	6×ST15	9×ST15	6×ST15	9×ST15	12×ST15	6×ST30	6×ST30	9×ST30
Overall length (mm)	A	190			230			250			280			360		
Flange outside diameter (mm)	B	198			220			270			318			428		
Flange outside diameter (mm)	B ₁	170			188			230			268			340		
Flange outside diameter (mm)	B ₂	170			188			230			306			390		
Flange centering diameter H7 (mm)	D ₁	90			110			140			174			210		
Flange centering diameter H7 (mm)	D ₂	90			110			140			200			210		
Hole circle diameter (mm)	E ₁	130			155.5			196			220			304		
Through hole diameter (mm)	F ₁	8x Ø13			8x Ø15			8x Ø17			12x Ø19			16x Ø22		
Bolt circle diameter (mm)	F ₂	130			155.5			196			270			350		
Thread size (mm)	F ₂	8x M12			8x M14			8x M16			12x M18			16x M20		
Flange thickness (mm)	l	14			17.5			20			22			25		
Fit length (mm)	J ₁	3			4			5			5			6		
Fit length (mm)	J ₂	2.5			3			3.5			4			4		
Distance (mm)	L	45			63.5			75			83.5			105.5		
Distance (mm)	M	83			113.5			125			124.5			165		
Actuation path (mm)	N	3.5			4.5			4.5			4.5			7.5		
Mounting diameter - elements (mm)	O	154			171			220			270			350		
Moment of inertia (approx.) D max. + max. sgmnt (10 ⁻³ kgm ²)	J.kst	83			150			380			830			3,300		
Speed max. (rpm)		9,000			7,500			6,300			5,000			3,600		
Allowable max. radial force standard* (KN)		7			12			17			22			30		
Approx. weight at D max. + max. sgmnt (kg)	m.kst	20			30.4			50.3			73			180		

* larger radial loads possible with special bearings

STE

200 – 14,000 Nm



Features

- Vibration damping
- Precise overload protection
- Wear resistant
- Press fit design
- With reinforced bearing suitable for extrusion machinery

Material

- High-quality, hardened steel.
- Corrosion resistant surface treatments

Design

- **Drive side:** hub with keyway connection
- **Output side:** flexible coupling and hub with simple keyway connection.
- **Safety elements:** The ST safety segments are evenly distributed around the circumference of the coupling. They ensure the safe disconnection of the driveline in the event of overload, and can be adjusted within a fixed range.

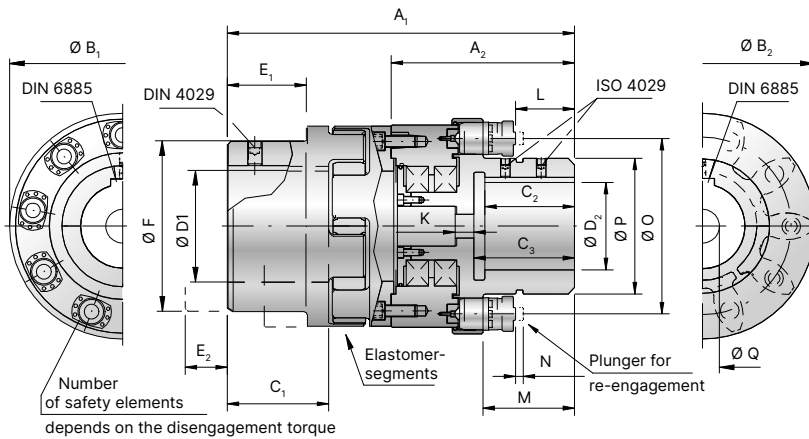

with integrated bearing
 Optionally available with fully split hubs

Model STE | Size 2-10

Size	2			5			10			
	Adjustment range available from to (KNm)	0.2-0.5	0.5-1.0	1.0-1.5	0.7-2	1.2-4	3.2-5	2-5	4-10	6-14
Elastomer coupling size		3×ST11	6×ST11	6×ST11	3×ST16	6×ST16	6×ST16	3×ST16	6×ST16	9×ST16
Elastomer insert type			A / B			A / B			A / B	
Overall length ±2 (mm)	A_1		312			373			460	
Length of torque limiting portion (mm)	A_2		170			190			230	
Flange outside diameter (ST portion) (mm)	B_1		198			220			270	
Flange outside diameter (elastomer portion) (mm)	B_2		160			225			290	
Fit length/keyway length D1 (mm)	C_1		88			113			142	
Fit length/keyway length D2 (mm)	C_2		85			100			122	
Bore depth (torque limiting portion) (mm)	C_3		95			111			122	
Bore diameter (elastomer portion) $\varnothing - \varnothing F7$ (mm)	D_1		30-95			40-130			50-170	
Bore diameter (torque limiting portion) $\varnothing - \varnothing F7$ (mm)	D_2		30-80			40-90			40-110	
Length (mm)	E_1		69			89			110	
Length (mm)	E_2		36			47			57	
Hub diameter (mm)	F		154			190			240	
Wall thickness (mm)	K		16			24			32	
Distance (mm)	L		50			56			74	
Distance (mm)	M		81			97			115	
Actuation path (mm)	N		3.5			4.5			4.5	
Mounting diameter - elements (mm)	O		154			171			220	
Hub outside diameter (mm)	P		112			122			170	
Bore for fastening screw (mm)	Q		max. $\varnothing 17$			max. $\varnothing 25$			max. $\varnothing 26$	
Moment of inertia (approx.) D max. + max. sgmnt (10^{-3}kgm^2)			145			337			1,145	
Speed max. (rpm)			8,500			6,300			5,000	
Approx. weight at D max. + max. sgmnt (kg)			35			47			110	
Axial (mm)			± 3			± 4			± 5	
Lateral Elastomer insert type A / B (mm)			0.5 / 0.3			0.5 / 0.3			0.6 / 0.4	
Angular Elastomer insert type A / B (degree)			1.5 / 1.0			1.5 / 1.0			1.5 / 1.0	
Dynamic torsional stiffness at T_{KN} (Elastomer insert type A / B) (10^3 Nm/rad)			175 / 216			337 / 743			1,180 / 1,340	

ST4

With simple keyway mounting and flexible gear coupling

200 – 250,000 Nm



Features

- High power density
- Compensation for misalignment
- Precise overload protection
- Low reaction loads on shaft bearings
- Extremely wear resistant
- With reinforced bearing

Material

- High-quality, hardened steel.
- Corrosion resistant surface treatments

Design

- **Drive side:** hub with keyway connection
- **Output side:** flexible gear coupling and hub with simple keyway connection.
- **Safety elements:** The ST safety segments are evenly distributed around the circumference of the coupling. They ensure the safe disconnection of the driveline in the event of overload, and can be adjusted within a fixed range.

Model ST4 | Size 2–25

Size		2			5			10			25			
Adjustment range available from to	(KNm)		0.2-0.5	0.5-1.0	1.0-1.5	0.7-2	1.2-4	3.2-6	2-5	4-10	6-14	3-6	5-12	9-19
			3×ST10	6×ST10	6×ST10	3×ST15	6×ST15	6 ST15	3×ST15	6×ST15	9×ST15	3×ST15	6× ST15	9×ST15
Overall length	(mm)	A ₁	300			355			410			490		
Flange outside diameter (ST portion)	(mm)	B ₁	198			220			270			318		
Mounting flange outside diameter (ST portion)	(mm)	B ₂	192			209			259			300		
Flange outside diameter (gear coupling)	(mm)	B ₃	168			200			225			265		
Hub diameter (gear coupling)	(mm)	B ₄	130.5			158.4			183.4			211.5		
Fit length/keyway length	(mm)	C _{1/2}	62			76			90			105		
Bore diameter Ø to Ø F7	(mm)	D _{1/2}	30-78			32-98			42-112			46-132		
Length	(mm)	E	63.5			78.5			92.5			108		
Screw	(mm)	F	6×M8			10×M12			12×M12			12×M16		
Tightening torque	(mm)	F	18			65			65			150		
Distance	(mm)	L	110			138			159.5			202		
Distance	(mm)	M	148			188			209.5			252		
Actuation path	(mm)	N	3.5			4.5			4.5			4.5		
Mounting diameter - elements	(mm)	O	154			171			220			270		
Moment of inertia (approx.) D max. + max. sgmnt	(10 ⁻³ kgm ²)		108			244			529			1,117		
Speed max.	(1/min.)		4,000			3,900			3,700			3,550		
Approx. weight at D max. + max. sgmnt	(kg)		25			45			65			100		
Axial	(mm)		1.5			2.5			2.5			3		
Angular	(degree)		2×0.35°			2×0.35°			2×0.35°			2×0.35°		

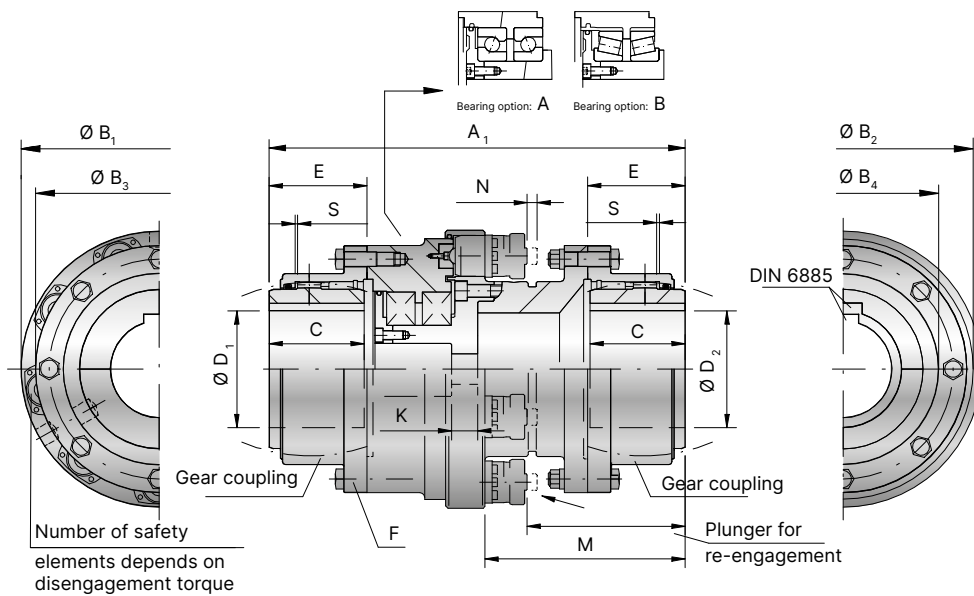

Model ST4 | Size 40–250

Size		40			60			100			160			250	
Adjustment range available from to	(KNm)	12-21	22-32	32-45	11-18	22-36	30-55	24-50	45-90	80-110	25-55	50-110	80-165	100-170	160-250
		6×ST30	6×ST30	9×ST30	3×ST30	6×ST30	9×ST30	3×ST70	6×ST70	9×ST70	3×ST70	6×ST70	9×ST70	8×ST71	12×ST71
Overall length	(mm)	A ₁	600			660			780			860		891	
Flange outside diameter (ST portion)	(mm)	B ₁	428			459			592			648		740	
Mounting flange outside diameter (ST portion)	(mm)	B ₂	399			418			560			618		724	
Flange outside diameter (gear coupling)	(mm)	B ₃	330			370			438			525		639	
Hub diameter (gear coupling)	(mm)	B ₄	275.5			307			367			423		505	
Fit length/keyway length	(mm)	C _{1/2}	135			150			190			220		220	
Bore diameter Ø to Ø F7	(mm)	D _{1/2}	60-174			70-190			110-233			120-280		200-280	
Length	(mm)	E	139			154			194			225		296	
Screw DIN 609 12.9	(mm)	F	14×M16			14×M18			14×M22			16×M24		22×M24	
Tightening torque	(mm)		150			220			400			520		520	
Distance	(mm)	L	238			275			318			360		458	
Distance	(mm)	M	306			343			408			450		534	
Actuation path	(mm)	N	8			8			10			10		10	
Mounting diameter - elements	(mm)	O	350			376			490			532		630	
Moment of inertia (approx.) D max. + max. sgmnt (10 ⁻³ kgm ²)			4,363			6,650			20,611			33,820		84,926	
Speed max.	(1/min.)		2,750			2,420			1,950			1,730		950	
Approx. weight at D max. + max. sgmnt	(kg)		225			293			570			718		1,110	
Axial	(mm)		4			4			4			5		6	
Angular	(degree)		2×0.35°			2×0.35°			2×0.35°			2×0.35°		2×0.35°	

ST5

With keyway connection and flexible coupling

200 – 19,000 Nm



Features

- Highly elastic damping
- Compensation of misalignments
- Precise torque limitation
- Puncture-proof
- Low backlash

Material

- High-quality, hardened steel.
- Rust protection due to oxidized surfaces.

Design

- **Drive side:** hub with keyway connection
- **Output side:** flexible pin and bushing coupling and hub with simple keyway connection.
- **Safety elements:** The ST safety segments are evenly distributed around the circumference of the coupling. They ensure the safe disconnection of the driveline in the event of overload, and can be adjusted within a fixed range.

Model ST5 | Size 2-5

Size			2			5		
Adjustment range available from - to	(KNm)		0.2-0.5	0.5-1.0	1.0 -1.5	0.7-2	1.2-4	3.2-5
			3×ST11	6×ST11	6×ST11	3×ST16	6×ST16	6×ST16
Overall length	(mm)	A ₁		245			273	
Length of torque limiting portion	(mm)	A ₂		170			190	
Diameter safety coupling	(mm)	B		198			220	
Fit length / keyway length elastomer portion	(mm)	C ₁		72			80	
Fit length / keyway length limiting portion	(mm)	C ₂		85			100	
Bore diameter elastomer portion	(mm)	D ₁		30-80			40-100	
Bore diameter torque limiting portion	(mm)	D ₂		30-80			40-90	
Hub diameter	(mm)	F		116			138	
Bore for fastening screw	(mm)	G		max. Ø 21			max. Ø 25	
Distance	(mm)	L		50			56	
Distance	(mm)	M		81			97	
Actuation path	(mm)	N		3			4.5	
Mounting diameter - elements	(mm)	O		154			171	
Moment of inertia (approx.) D max. + max. sgmnt	(10 ⁻³ kgm ²)			133			216	
Speed max.	(1/min.)			8,500			6,300	
Approx. weight at D max. + max. sgmnt	(kg)			33			39	
Axial	(mm)			1.3			1.3	
Lateral	(mm)			0.56			0.56	
Angular	(degree)			0.18			0.16	
Dynamic torsional stiffness T _{KN} (Standard A)	(10 ³ Nm/rad)			130			200	

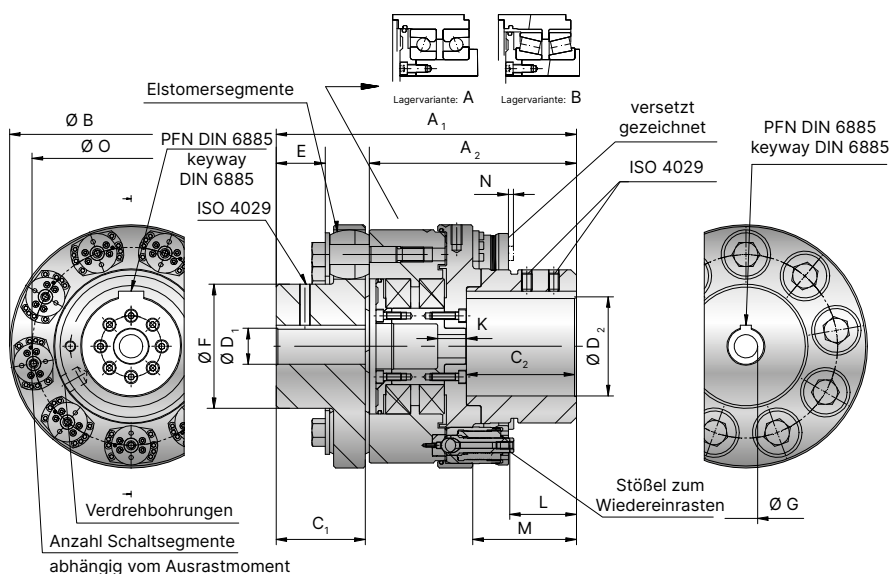

Model ST5 | Size 10–25

Higher torque on request

Size		10			25			
Adjustment range available from - to	(KNm)		2-5	4-10	6-14	3-6	5-12	9-19
			3×ST16	6×ST16	9×ST16	3×ST16	6×ST16	9×ST16
Overall length	(mm)	A_1	334			385		
Length of torque limiting portion	(mm)	A_2	230			264		
Diameter safety coupling	(mm)	B	270			318		
Fit length / keyway length elastomer portion	(mm)	C_1	99			116		
Fit length / keyway length limiting portion	(mm)	C_2	122			150		
Bore diameter elastomer portion	(mm)	D_1	40-105			60-130		
Bore diameter torque limiting portion	(mm)	D_2	40-110			60-140		
Hub diameter	(mm)	F	138			186		
Bore for fastening screw	(mm)	G	max. \varnothing 26			max. \varnothing 32		
Distance	(mm)	L	74			97		
Distance	(mm)	M	115			138		
Actuation path	(mm)	N	4.5			4.5		
Mounting diameter - elements	(mm)	O	220			270		
Moment of inertia (approx.) D max. + max. sgmnt	(10^{-3} kgm ²)		622			1,300		
Speed max.	(1/min.)		5,000			4,000		
Approx. weight at D max. + max. sgmnt	(kg)		76			114		
Axial	(mm)		2.25			2.25		
Lateral	(mm)		0.91			0.91		
Angular	(degree)		0.21			0.18		
Dynamic torsional stiffness T_{KN} (Standard A)	(10^3 Nm/rad)		350			740		

ST

Accessories TORQSET® Safety element



Material

Hardened steel (nitrocarburized surface)
Corrosion resistant surface treatments

Design

Two part assembly for installation into prefabricated coupling components.

Part 1: detent receptacle

Part 2: self-contained, spring loaded plunger module. The spring force setting is adjustable in the field, with the settings clearly marked on an adjustment scale.

Re-engagement

When properly located over the detent receptacle the safety element can be re-engaged through the application of pressure to the back side of the plunger core.

Model ST | Size 10 – 30

Size			10	15	30
Tangential force (KN) Adjustment range available from - to	(ranges)	1	0.8-2.2	1-4	5-10
		2	2.0-3.3	2-8	10-20
		3	3.2-8	6-15	20-32
Centering diameter of safety element g6	(mm)	A ₁	28	40	70
Centering diameter engagement receptacle g6	(mm)	A ₂	18	24	34
Centering length of safety element	(mm)	B ₁	15	20	35
Centering length engagement receptacle	(mm)	B ₂	13.5	14	22
Overall length	(mm)	C	56	70	103
Outside diameter	(mm)	D ₁	45	59	100
Bolt circle diameter	(mm)	D ₂	37.5	50	86
Diameter plunger	(mm)	D ₃	8	16	28
Diameter adjustment nut	(mm)	D ₄	32	44	75
Screw / Tightening torque ISO 4762	(mm)	E ₁	6 x M4 x 12 / 4.5 Nm	6 x M5 x 16 / 10 Nm	6 x M8 x 25 / 40 Nm
Screw / Tightening torque ISO 4762	(mm)	E ₂	M3 x 20 4.5 Nm	M4 x 14 4.5 Nm	M6 x 20 15.5 Nm
Flange thickness	(mm)	F	5	7	12
Distance	(mm)	G	6.5	5	8
Actuation path	(mm)	H	3	4	7.5
Distance	(mm)	I	1.5	2	3
Radius	(mm)	J	100	110	200
Inner thread	(mm)	K	M5 x 10	M8 x 15	M10 x 25
Distance ± 0,1	(mm)	L	30	36	60
Weight	(kg)		0.26	0.65	2.7

axial spring force ≈ tangential force/1.4

Design:

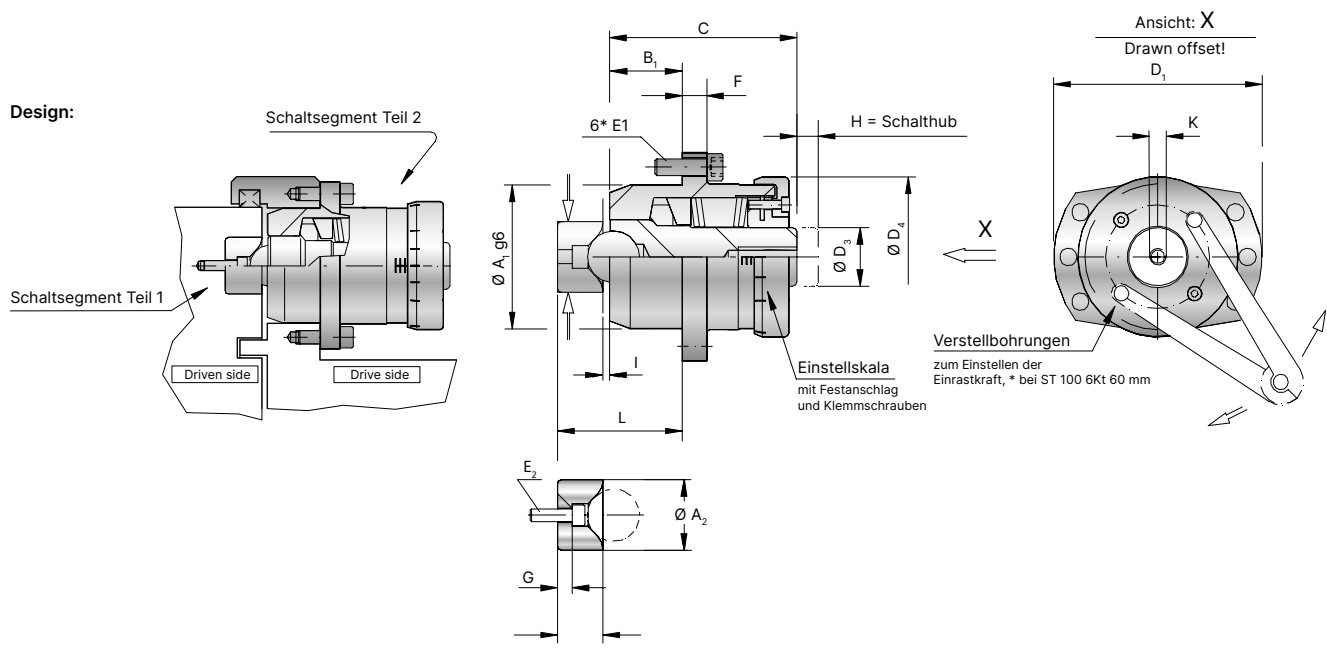

Model ST | Size 70-100

Size			70	100
Tangential force (KN) Adjustment range available from - to	(ranges)	1	8-20	
		2	15-40	52-88
		3	30-70	70-120
Centering diameter of safety element g6	(mm)	A ₁	90	120
Centering diameter engagement receptacle g6	(mm)	A ₂	44	60
Centering length of safety element	(mm)	B ₁	45	80.5
Centering length engagement receptacle	(mm)	B ₂	30	40.5
Overall length	(mm)	C	135	240
Outside diameter	(mm)	D ₁	129	160
Bolt circle diameter	(mm)	D ₂	110	
Diameter plunger	(mm)	D ₃	35	
Diameter adjustment nut	(mm)	D ₄	92	98
Screw / Tightening torque ISO 4762	(mm)	E ₁	6 x M12 x 35 / 120 Nm	6 x M12 x 40 (12.9) 120 Nm
Screw / Tightening torque ISO 4762	(mm)	E ₂	M8 x 25 38 Nm	M10 x 25 38 Nm
Flange thickness	(mm)	F	16	18
Distance	(mm)	G	10	
Actuation path	(mm)	H	10	12.5
Distance	(mm)	I	4	5
Radius	(mm)	J	250	315
Inner thread	(mm)	K	M16 x 30	SW 36
Distance ± 0,1	(mm)	L	79	79
Weight	(kg)		6	14.8

Accessories TORQSET® Safety element

Engagement and disengagement

Order number

Size	Engagement/ disengagement tool
10	Order number AV / 0010
15	Order number AV / 0015
30	Order number AV / 0030
70	Order number AV / 0070
100	on request

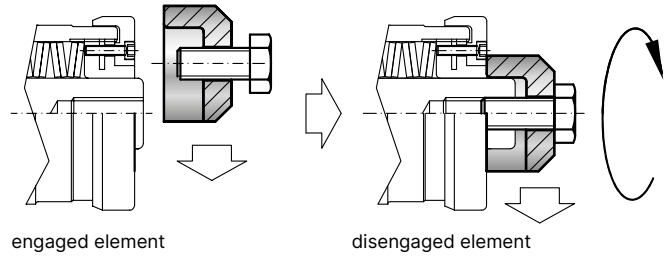

Adjustment wrench

Order number

Size	Adjustment wrench
10	Order number SLS / 0010
15	Order number SLS / 0015
30	Order number SLS / 0030
70	Order number SLS / 0070
100	on request

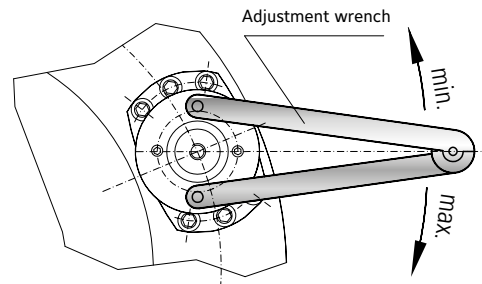

Switch plate

Switch plates are available on request for all models and sizes. Contact R+W for more information.

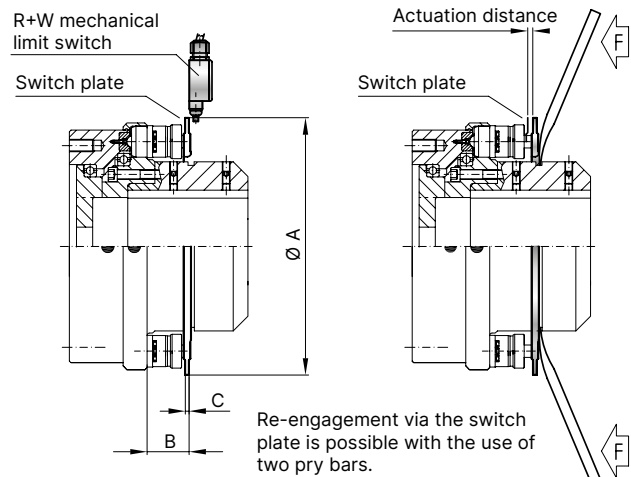

Accessories TORQSET® Safety element

Proximity switch

Order number 650.2703.001

Technical data	ST
Voltage	10 to 30 V DC
Max. output current	200 mA
Max. switch frequency	800 KHz
Temperature range	-25° to +70° C
Protective system	IP 67
Switch type	normally open
Max. detection gap	max. 2 mm

Switch diagram ST

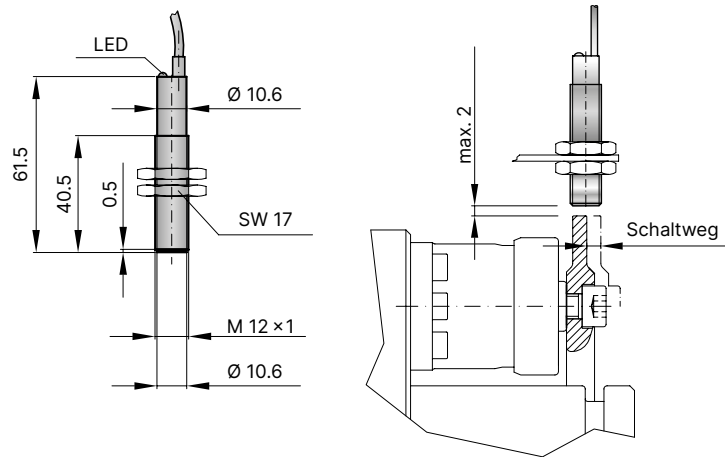
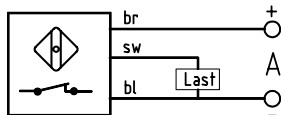

Mechanical limit switch

Order number 618.3000.313

Technical data	ST
Max. voltage	250 V AC
Protective system	IP 67
Contact system	2 Opener (forced separating)
Temperature range	-30° to +80° C
Actuation	Plunger (metal)

Switch diagram ST

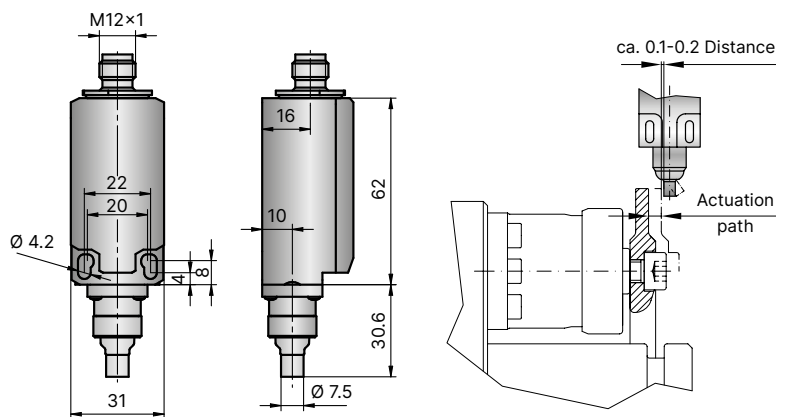
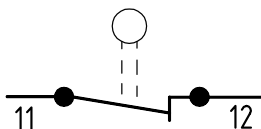

The switch plunger (pictured above and right) should be located as close to the actuation ring / limit switch plate as possible (approximately 0.1-0.2mm).

ST

Accessories TORQSET® Safety element

ATEX limit switch

Order number EEX. 1624.004

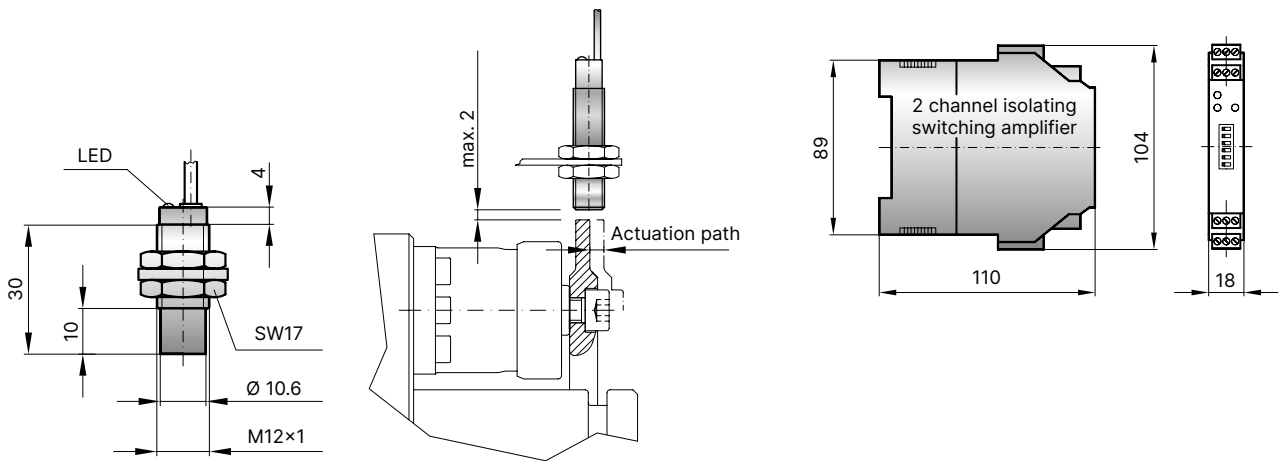

Switch diagram

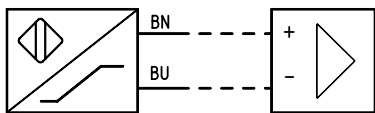

Technical data on request.

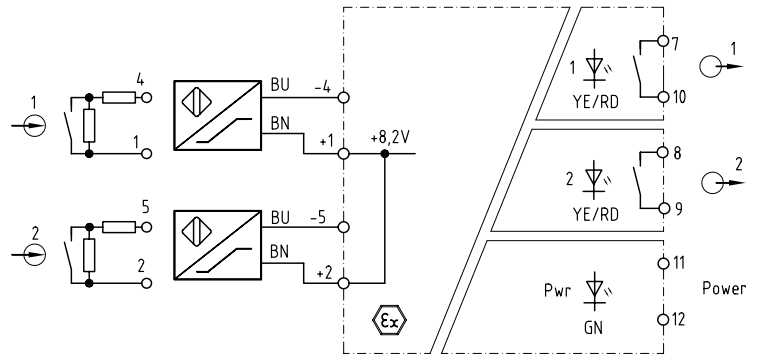



With torsionally stiff flexible bellows coupling

- With clamping hubs, keyway connection or flange connection
- Compensates for misalignment
- With metal bellows made of highly elastic stainless steel



For high speed applications

- Integral ball-plunger system
- Extremely compact with a low moment of inertia
- Balanced for high speed



**BUREAU
VERITAS**

Bureau Veritas certified

- For inland and offshore applications
- Customized solutions
- Rugged and special design for direct use in ship powertrains





Torsionally stiff disc pack couplings

350 – 50,000 Nm

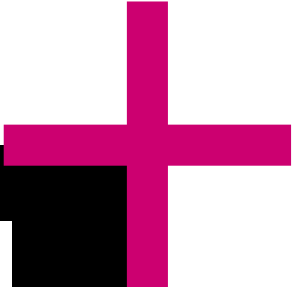

DISC PACK COUPLINGS
LP

Areas of application

- + Paper machinery
- + Steel mill equipment
- + Test stands
- + Generators
- + Bulk material handling systems
- + Centrifuges
- + Cooling tower drives
- + Compressors
- + Printing machinery
- + For infinite life in extreme conditions

Service life

R+W disc pack couplings are fatigue resistant and wear free for a virtually infinite service life, as long as the technical limits are not exceeded.

Fit clearance

Overall shaft / hub clearance of 0.01 - 0.05 mm

Temperature range

-30°C to +280°C

Rotational speed

see table

Delivery

pre-assembled (separate components on request)

ATEX (Optional)





Available on request.

Ordering example	LP1	700	D	154	25	56	XX
Model	●						Special designation only (e.g. special bore diameter tolerances, balancing, etc.). Contact R+W for more information
Size		●					
Type (S or D)			●				
Overall length (mm)				●			
Bore diameter Ø D1 H7					●		
Bore diameter Ø D2 H7						●	

For custom features place an XX at the end of the part number and describe the special requirements (e.g. LP1 / 700 / D / 154 / 25 / 56 / XX - balanced for 8,000 rpm)

Torsionally stiff disc pack couplings

350 – 50,000 Nm

Model		Features	Page
LP1 S		<p>With keyway mounting single flex design 350 – 50,000 Nm</p> <ul style="list-style-type: none"> • Extremely high torsional stiffness • Compact and robust design • Compensates for axial and angular misalignment only 	44
LP1 D		<p>With keyway mounting dual flex design 350 – 50,000 Nm</p> <ul style="list-style-type: none"> • High torsional stiffness • Robust design • Compensates for axial, angular and lateral misalignment 	45
LP2		<p>With keyway mounting dual flex design with spacer 350 – 50,000 Nm</p> <ul style="list-style-type: none"> • High torsional stiffness • Customer specified length on request • Compensates for axial, angular and lateral misalignment 	46-47
LP4 S		<p>With conical clamping ring single flex design 350 – 50,000 Nm</p> <ul style="list-style-type: none"> • Extremely high torsional stiffness • Compact design • Good for reversing loads • Zero backlash torque transmission • Compensates for axial and angular misalignment only 	48
LP4 D		<p>With conical clamping ring dual flex design 350 – 50,000 Nm</p> <ul style="list-style-type: none"> • High torsional stiffness • Good for reversing loads • Zero backlash torque transmission • Compensates for axial, angular and lateral misalignment 	49

Model	Features	Page	
<div style="border: 1px solid black; padding: 2px; display: inline-block;">LP3</div>		<p>With conical clamping ring dual flex design 350 – 50,000 Nm</p> <ul style="list-style-type: none"> • High torsional stiffness • High clamping pressure • Good for reversing loads • Zero backlash torque transmission • Compensates for axial, angular and lateral misalignment 	50-51
<div style="border: 1px solid black; padding: 2px; display: inline-block;">LP5 S</div>		<p>With clamping hub single flex design 350 – 30,000 Nm</p> <ul style="list-style-type: none"> • Extremely high torsional stiffness • Compact and robust design • Zero backlash torque transmission • Keyway optional • Compensates for axial and angular misalignment only 	52
<div style="border: 1px solid black; padding: 2px; display: inline-block;">LP5 D</div>		<p>With clamping hub dual flex design 350 – 30,000 Nm</p> <ul style="list-style-type: none"> • High torsional stiffness • Zero backlash torque transmission • Keyway optional • Compensates for axial, angular and lateral misalignment 	53
<div style="border: 1px solid black; padding: 2px; display: inline-block;">LPH</div>		<p>With fully split clamping hub dual flex design 350 – 50,000 Nm</p> <ul style="list-style-type: none"> • High torsional stiffness • Facilitates lateral mounting • Zero backlash torque transmission • Keyway optional • Compensates for axial, angular and lateral misalignment 	54-55
<div style="border: 1px solid black; padding: 2px; display: inline-block;">LPZ</div>		<p>Short intermediate spacer for dual flex configurations 350 – 50,000 Nm</p> <ul style="list-style-type: none"> • High torsional stiffness • For combination with various hub designs • Compensates for axial, angular and lateral misalignment 	56

LP1 S

With keyway mounting; single flex

350 – 50,000 Nm



Features

- Extremely high torsional stiffness
- Wear and maintenance free
- Compensates for axial and angular misalignment only

Material

- **Disc pack:** highly elastic spring steel
- **Hubs:** high strength steel

Design

Two precision machined coupling hubs mounted to the disc pack by means of high strength screws and bushings for alignment and frictional clamping of the assembly. Axial retention of the hubs on the shaft with DIN 916 set screws.

From series 25,000 assembly screws/superbolts must be used.

S = single flex design

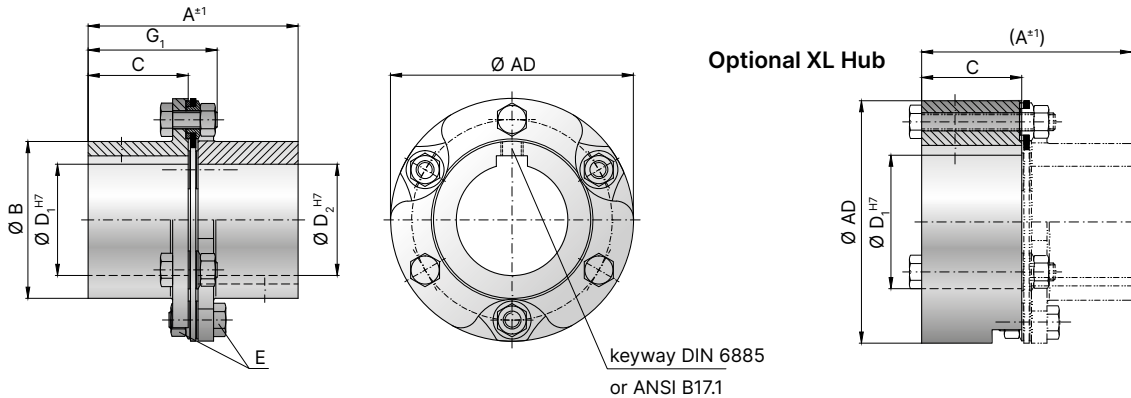

Model LP1 S | Size 300–25,000

Higher torques on request

Size			300	500	700	1,100	1,600	2,600	4,000	6,000	8,000	15,000	25,000
Rated torque	(Nm)	T_{KN}	350	500	700	1,100	1,600	2,600	4,000	6,000	8,000	15,000	25,000
Maximum torque	(Nm)	T_{KNmax}	700	1,000	1,400	2,200	3,200	5,200	8,000	12,000	16,000	30,000	50,000
Overall length	(mm)	A	95	95	116	117	158	161	193	193	216	264.7	346.7
Outside diameter	(mm)	$\varnothing AD$	99	109	128	133	150	168	198	212	238	272	300
Hub diameter	(mm)	$\varnothing B$	63	70.5	78	84	86	102	120	130	140	182	189
Hub fit length	(mm)	C	45	45	55	55	75	76	90	90	100	125	165
Bore diameter available from \varnothing to $\varnothing H7$	(mm)	$D_{1/2}$	18 - 48	23 - 50	25 - 58	25 - 60	28 - 64	31 - 75	38 - 90	39 - 95	50 - 102	70 - 140	75 - 145
Bore diameter available from \varnothing to $\varnothing H7$ (XL Hub)	(mm)	$D_{1/2}$	> 48 - 53	> 50 - 60	> 58 - 65	> 60 - 70	> 64 - 80	> 75 - 90	> 90 - 100	> 95 - 115	> 102 - 125	> 140 - 160	> 145 - 170
Assembly screw (ISO 4017) Tensioning nut (DIN 4032)		E	M8	M8	M10	M10	M12	M12	M16	M16	M20	M20	M24
Tightening torque	(Nm)		35	40	65	95	150	165	360	400	755	770	47
Distance between hubs	(mm)	G	-	-	-	-	-	-	-	-	-	-	-
Assembly length	(mm)	G_1	60	60	75	75	98	99	120	120	140	165	227.8
Moment of inertia**	(10^{-3}kgm^2)	$J_{ges.}$	1.7	3	5	6.4	11.3	20	46	61	118	261	471
Weight**	(kg)		1.5	2.0	2.9	3.4	5	6.8	11.1	13	19.4	30.5	46.5
Torsional stiffness disc packs	(kNm/rad)	C_T	200	280	470	540	800	1,200	2,000	2,500	3,600	7,700	16,000
Axial \pm	(mm)		0.5	0.6	0.7	0.8	1.0	1.1	1.3	1.3	1.3	1.5	1.5
Lateral \pm	(mm)	max. values	-	-	-	-	-	-	-	-	-	-	-
Angular \pm	(degree)		0.7	0.7	0.7	0.7	0.7	0.7	0.7	0.7	0.7	0.7	0.7
Max. speed	(min^{-1})		5,800	5,200	4,500	4,300	3,850	3,500	2,950	2,700	2,400	2,100	1,900
Max. speed (balanced)***	(min^{-1})		13,500	12,300	10,500	10,000	8,950	8,000	6,700	6,300	5,600	4,900	4,500

** at maximum bore diameter | *** higher speeds on request

LP1 D

With keyway mounting; dual flex

350 – 50,000 Nm



Features

- High torsional stiffness
- Wear and maintenance free
- Compensates for axial, angular and lateral misalignment

Material

- **Disc pack:** Hochelastischer Federstahl
- **Hubs and spacer:** high strength steel

Design

Two precision machined coupling hubs and spacer plate mounted to the disc packs by means of high strength screws and bushings for alignment and frictional clamping of the assembly. Axial retention of the hubs on the shaft with DIN 916 set screws.

From series 25,000 assembly screws/superbolts must be used.

D = dual flex design

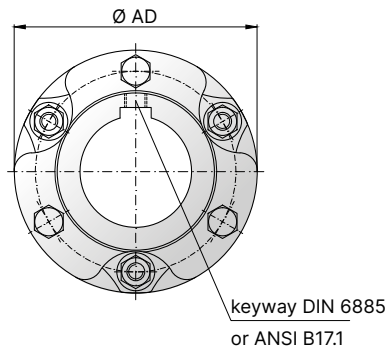
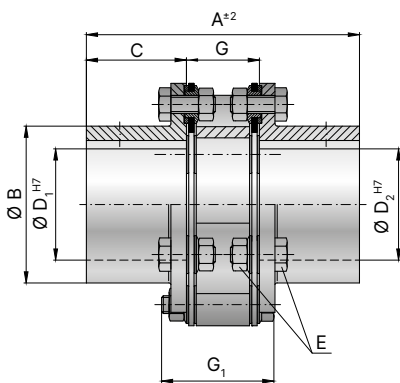

Optional XL Hub

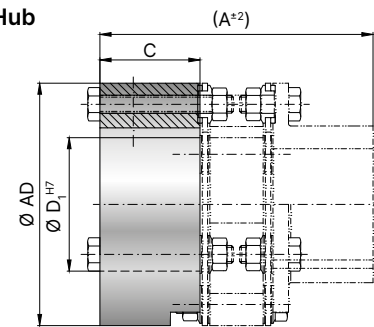

Model LP1 D | Size 300–25,000

Higher torques on request

Size			300	500	700	1,100	1,600	2,600	4,000	6,000	8,000	15,000	25,000
Rated torque	(Nm)	T_{KN}	350	500	700	1,100	1,600	2,600	4,000	6,000	8,000	15,000	25,000
Maximum torque	(Nm)	T_{KNmax}	700	1,000	1,400	2,200	3,200	5,200	8,000	12,000	16,000	30,000	50,000
Overall length	(mm)	A	123	123	154	158	204	208	250	258	297	336.4	468.4
Outside diameter	(mm)	Ø AD	99	109	128	133	150	168	198	212	238	272	300
Hub diameter	(mm)	Ø B	63	70.5	78	84	86	102	120	130	140	182	189
Hub fit length	(mm)	C	45	45	55	55	75	76	90	90	100	125	165
Bore diameter available from Ø to Ø H7	(mm)	$D_{1/2}$	18 - 48	23 - 50	25 - 58	25 - 60	28 - 64	31 - 75	38 - 90	39 - 95	50 - 102	70 - 140	75 - 145
Bore diameter available from Ø to Ø H7 (XL Hub)	(mm)	$D_{1/2}$	> 48 - 53	> 50 - 60	> 58 - 65	> 60 - 70	> 64 - 80	> 75 - 90	> 90 - 100	> 95 - 115	> 102 - 125	> 140 - 160	> 145 - 170
Assembly screw (ISO 4017) Tensioning nut (DIN 4032)		E	M8	M8	M10	M10	M12	M12	M16	M16	M20	M20	M24
Tightening torque	(Nm)		35	40	65	95	150	165	360	400	755	770	47
Distance between hubs	(mm)	G	33	33	44	48	54	56	70	78	97	86.4	138.4
Assembly length	(mm)	G_1	50.3	50.3	61.4	66.4	77.5	77.5	100	110	132.5	132.5	230.6
Moment of inertia**	(10^{-3}kgm^2)	$J_{ges.}$	2.6	4	9	10.5	18	32	74	100	200	400	928
Weight**	(kg)		2.2	2.9	4.4	5.2	7.3	10	16	19.5	30.2	44	92.5
Torsional stiffness disc packs	(kNm/rad)	C_T	100	140	235	270	400	600	1,000	1,250	1,800	3,850	8,000
Axial ±	(mm)		1.0	1.0	1.5	1.5	2.0	2.0	2.5	2.5	2.5	3.0	4.0
Lateral ±	(mm)	$max. values$	0.2	0.2	0.3	0.3	0.4	0.4	0.5	0.5	0.6	0.7	0.8
Angular ±	(degree)		1.4	1.4	1.4	1.4	1.4	1.4	1.4	1.4	1.4	1.4	1.4
Max. Drehzahl	(min^{-1})		5,800	5,200	4,500	4,300	3,850	3,500	2,950	2,700	2,400	2,100	1,900
Max. speed (balanced)***	(min^{-1})		13,500	12,300	10,500	10,000	8,950	8,000	6,700	6,300	5,600	4,900	4,500

** at maximum bore diameter | *** higher speeds on request

LP2

With keyway mounting

350 – 5,200 Nm



Features

- High torsional stiffness
- Dual flex design
- Customer specified length on request

Material

- **Disc pack:** highly elastic spring steel
- **Hubs and spacer:** high strength steel

Design

Two precision machined coupling hubs and spacer mounted to the disc packs by means of high strength screws and bushings for alignment and frictional clamping of the assembly. Axial retention of the hubs on the shaft with DIN 916 set screws.

From series 25,000 assembly screws/superbolts must be used.

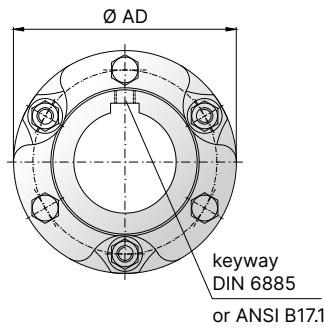
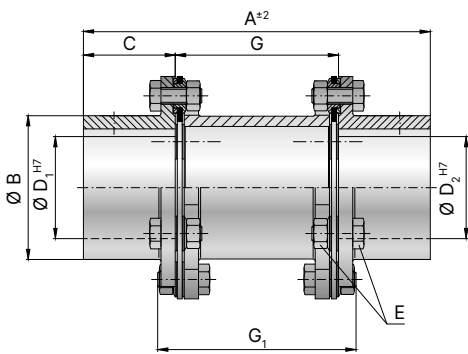

Optional XL Hub

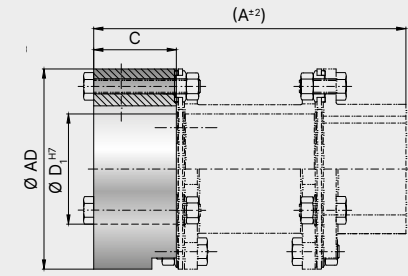

Model LP2 | Size 300–2,600

Higher torques on request

Size			300	500	700	1,100	1,600	2,600
Rated torque	(Nm)	T_{KN}	350	500	700	1,100	1,600	2,600
Maximum torque	(Nm)	T_{KNmax}	700	1,000	1,400	2,200	3,200	5,200
Overall length	(mm)	A	170	170	205	206	286	286
Outside diameter	(mm)	Ø AD	99	109	128	133	150	168
Hub diameter	(mm)	Ø B	63	70.5	78	84	86	102
Hub fit length	(mm)	C	45	45	55	55	75	76
Bore diameter available from Ø to Ø H7	(mm)	$D_{1/2}$	18 - 48	23 - 50	25 - 58	25 - 60	28 - 64	31 - 75
Bore diameter available from Ø to Ø H7 (XL Hub)	(mm)	$D_{1/2}$	> 48 - 53	> 50 - 60	> 58 - 65	> 60 - 70	> 64 - 80	> 75 - 90
Assembly screw (ISO 4017) Tensioning nut (DIN 4032)		E	M8	M8	M10	M10	M12	M12
Tightening torque	(Nm)		35	40	65	95	150	165
Distance between hubs	(mm)	G	80	80	95	96	136	134
Assembly length	(mm)	G_1	100	100	123	124	166	162
Moment of inertia**	($10^{-3}kgm^2$)	J_{ges}	4	5	9	11	20	35
Weight**	(kg)		2.6	3.5	4.8	5.4	8.5	12
Torsional stiffness disc packs	(kNm/rad)	C_T	100	140	235	270	400	600
Axial ±	(mm)		1	1	1.5	1.5	2	2
Lateral ±	(mm)	max. values	0.8	0.8	1	1	1.4	1.4
Angular ±	(degree)		1.4	1.4	1.4	1.4	1.4	1.4
Max. speed	(min ⁻¹)		5,800	5,200	4,500	4,300	3,850	3,500
Max. speed (balanced)***	(min ⁻¹)		13,500	12,300	10,500	10,000	8,950	8,000

** at maximum bore diameter | *** higher speeds on request

LP2

With keyway mounting

4,000 – 50,000 Nm



Features

- High torsional stiffness
- Dual flex design
- Customer specified length on request

Material

- **Disc pack:** highly elastic spring steel
- **Hubs and spacer:** high strength steel

Design

Two precision machined coupling hubs and spacer mounted to the disc packs by means of high strength screws and bushings for alignment and frictional clamping of the assembly. Axial retention of the hubs on the shaft with DIN 916 set screws.

From series 25,000 assembly screws/superbolts must be used.

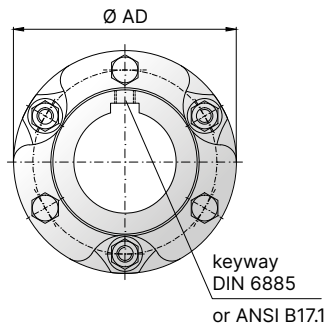
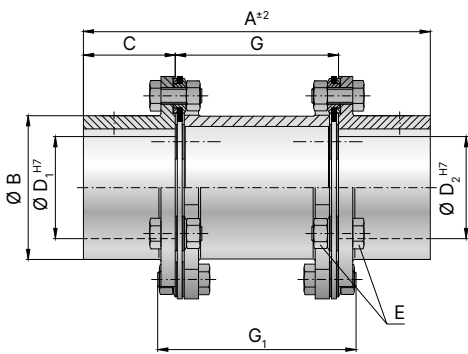

Optional XL Hub

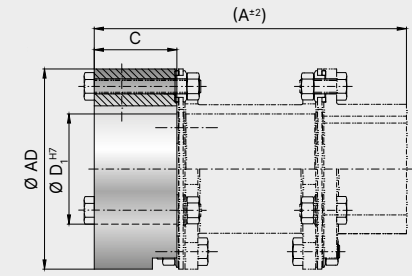

Model LP2 | Size 4,000–25,000

Higher torques on request

Size			4,000	6,000	8,000	15,000	25,000
Rated torque	(Nm)	T_{KN}	4,000	6,000	8,000	15,000	25,000
Maximum torque	(Nm)	T_{KNmax}	8,000	12,000	16,000	30,000	50,000
Overall length	(mm)	A	320	340	372	474	669.4
Outside diameter	(mm)	$\varnothing AD$	198	212	238	272	300
Hub diameter	(mm)	$\varnothing B$	120	130	140	182	189
Hub fit length	(mm)	C	90	90	100	125	165
Bore diameter available from \varnothing to $\varnothing H7$	(mm)	$D_{1/2}$	38 - 90	39 - 95	50 - 102	70 - 140	75 - 145
Bore diameter available from \varnothing to $\varnothing H7$ (XL Hub)	(mm)	$D_{1/2}$	> 90 - 100	> 95 - 115	> 102 - 125	> 140 - 160	> 145 - 170
Assembly screw Tensioning nut	(ISO 4017) (DIN 4032)	E	M16	M16	M20	M20	M24
Tightening torque	(Nm)		360	400	755	770	47
Distance between hubs	(mm)	G	140	160	172	224	339.4
Assembly length	(mm)	G_1	174	194	220	274.6	431.6
Moment of inertia**	($10^{-3}kgm^2$)	J_{ges}	81	109	216	448	870
Weight**	(kg)		18.4	21.3	33	48.9	82
Torsional stiffness disc packs	(kNm/rad)	C_T	1,000	1,250	1,800	3,850	8,000
Axial \pm	(mm)		2.5	2.5	2.5	3	4
Lateral \pm	(mm)	max. values	1.4	1.5	1.6	2.2	2.6
Angular \pm	(degree)		1.4	1.4	1.4	1.4	1.4
Max. speed	(min ⁻¹)		2,900	2,700	2,400	2,100	1,900
Max. speed (balanced)***	(min ⁻¹)		6,700	6,300	5,600	4,900	4,500

** at maximum bore diameter | *** higher speeds on request

DISC PACK COUPLINGS
LP

LP4 S

With conical clamping ring single flex

350 – 50,000 Nm



Features

- Extremely high torsional stiffness
- Good for reversing loads
- Compensates for axial and angular misalignment only

Material

- **Disc pack:** highly elastic spring steel
- **Hubs:** high strength steel

Design

Two precision machined coupling hubs with conical clamping ring mounted to the disc pack by means of high strength screws and bushings for alignment and frictional clamping of the assembly. From series 25,000 assembly screws/superbolts must be used.

S = single flex design

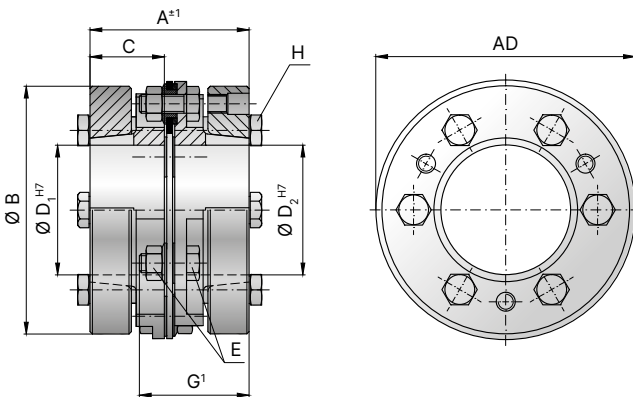

Model LP4 S | Size 300 – 25,000

Size			300	500	700	1,100	1,600	2,600	4,000	6,000	8,000	15,000	25,000
Rated torque*	(Nm)	T_{KN}	350	500	700	1,100	1,600	2,600	4,000	6,000	8,000	15,000	25,000
Maximum torque*	(Nm)	T_{KNmax}	700	1,000	1,400	2,200	3,200	5,200	8,000	12,000	16,000	30,000	50,000
Overall length	(mm)	A	76	76	93	99	120	136	161	174	226	238.7	264.7
Outside diameter	(mm)	Ø AD	99	109	128	133	150	168	198	212	238	272	300
Hub diameter	(mm)	Ø B	95	105	122	130	146	165	184	205	230	269	295
Hub fit length	(mm)	C	35.5	35.5	43.3	46	56	63.5	74	80.5	105	112	124
Bore diameter available from Ø to Ø H7	(mm)	$D_{1/2}$	24 - 50	24 - 55	30 - 65	30 - 65	35 - 70	35 - 85	50 - 100	50 - 110	60 - 115	70 - 150	90 - 170
Assembly screw Tensioning nut	(ISO 4017) (DIN 4032)	E	M8	M8	M10	M10	M12	M12	M16	M16	M20	M20	M24
Tightening torque	(Nm)		35	40	65	95	150	165	360	400	755	770	47
Distance between hubs	(mm)	G	-	-	-	-	-	-	-	-	-	-	-
Assembly length	(mm)	G_1	50.5	50.5	63.5	66	79	86.5	104	110.5	145	152	186.8
Clamping screw	(ISO 4017)	H	6 x M8	6 x M8	6 x M10	6 x M10	6 x M12	6 x M12	6 x M16	6 x M16	6 x M20	6 x M20	6 x M20
Tightening torque	(Nm)		20	26	39	61	98	140	225	308	490	620	620
Moment of inertia**	($10^{-3}kgm^2$)	$J_{ges.}$	3	5	12	16	30	57	106	168	371	716	1,062
Weight**	(kg)		2.5	3.0	5	6.7	9.6	13.6	19.5	25.3	45.4	62	75
Torsional stiffness disc packs	(kNm/rad)	C_T	200	280	470	540	800	1,200	2,000	2,500	3,600	7,700	16,000
Axial ±	(mm)		0.5	0.6	0.7	0.8	1.0	1.1	1.3	1.3	1.3	1.5	1.5
Lateral ±	(mm)	max. values	-	-	-	-	-	-	-	-	-	-	-
Angular ±	(degree)		0.7	0.7	0.7	0.7	0.7	0.7	0.7	0.7	0.7	0.7	0.7
Max. speed	(min^{-1})		5,800	5,200	4,500	4,300	3,850	3,500	2,900	2,700	2,400	2,100	1,900
Max. speed (balanced)***	(min^{-1})		13,500	12,300	10,500	10,000	8,950	8,000	6,700	6,300	5,600	4,900	4,500

* maximum transmittable torque depends on the bore diameter | ** at maximum bore diameter | *** higher speeds on request

LP4 D

With conical clamping ring dual flex

350 – 50,000 Nm



Features

- High torsional stiffness
- Good for reversing loads
- Compensates for axial, angular and lateral misalignment

Material

- **Disc pack:** hochelastischer Federstahl
- **Hubs and spacer:** high strength steel

Design

Two precision machined coupling hubs with conical clamping ring and spacer plate mounted to the disc packs by means of high strength screws and bushings for alignment and frictional clamping of the assembly.

D = dual flex design

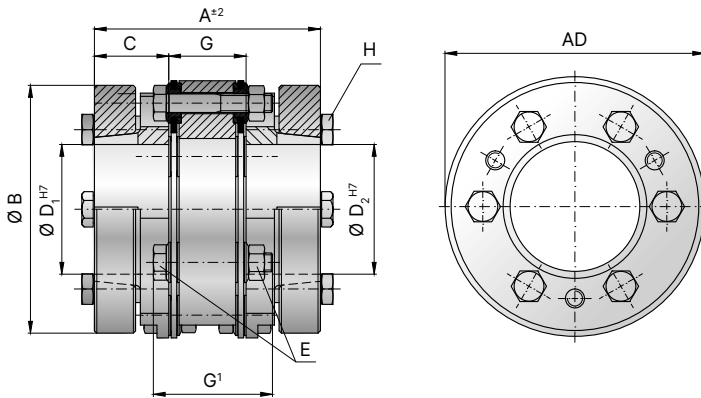

Model LP4 D | Size 300 – 25,000

Size			300	500	700	1,100	1,600	2,600	4,000	6,000	8,000	15,000	25,000	
Rated torque*	(Nm)	T_{KN}	350	500	700	1,100	1,600	2,600	4,000	6,000	8,000	15,000	25,000	
Maximum torque*	(Nm)	T_{KNmax}	700	1,000	1,400	2,200	3,200	5,200	8,000	12,000	16,000	30,000	50,000	
Overall length	(mm)	A	104	104	131	140	166	183	218	239	307	310.4	386.4	
Outside diameter	(mm)	Ø AD	99	109	128	133	150	168	198	212	238	272	300	
Hub diameter	(mm)	Ø B	95	105	122	130	146	165	184	205	230	269	295	
Hub fit length	(mm)	C	35.5	35.5	43.3	46	56	63.5	74	80.5	105	112	124	
Bore diameter available from Ø to Ø H7	(mm)	$D_{1/2}$	24 - 50	24 - 55	30 - 65	30 - 65	35 - 70	35 - 85	50 - 100	50 - 110	60 - 115	70 - 150	90 - 170	
Assembly screw	(ISO 4017)	E	M8	M8	M10	M10	M12	M12	M16	M16	M20	M20	M24	
Tensioning nut	(DIN 4032)													
Tightening torque	(Nm)		35	40	65	95	150	165	360	400	755	770	47	
Distance between hubs	(mm)	G	33	33	44	48	54	56	70	78	97	86.4	138.4	
Assembly length	(mm)	G_1	50.3	50.3	61.4	66.4	77.5	77.5	100	110	132.5	132.5	230.6	
Clamping screw	(ISO 4017)	H	6 x M8	6 x M8	6 x M10	6 x M10	6 x M12	6 x M12	6 x M16	6 x M16	6 x M20	6 x M20	6 x M20	
Tightening torque	(Nm)			20	26	39	61	98	140	225	308	490	620	620
Moment of inertia**	(10^{-3}kgm^2)	$J_{ges.}$	4	7	15	20	38	69	134	207	453	853	1,463	
Weight**	(kg)		3.2	3.9	6.5	7.9	12.0	16.7	24.7	32	56.5	75.4	108.3	
Torsional stiffness disc packs (kNm/rad)		C_T	100	140	235	270	400	600	1,000	1,250	1,800	3,850	8,000	
Axial ±	(mm)	max. values	1.0	1.0	1.5	1.5	2.0	2.0	2.5	2.5	2.5	3.0	4.0	
lateral ±	(mm)			0.2	0.2	0.3	0.3	0.4	0.4	0.5	0.5	0.6	0.7	0.8
Angular ±	(degree)			1.4	1.4	1.4	1.4	1.4	1.4	1.4	1.4	1.4	1.4	1.4
Max. speed	(min^{-1})		5,800	5,200	4,500	4,300	3,850	3,500	2,900	2,700	2,400	2,100	1,900	
Max. speed (balanced)***	(min^{-1})		13,500	12,300	10,500	10,000	8,950	8,000	6,700	6,300	5,600	4,900	4,500	

* maximum transmittable torque depends on the bore diameter | ** at maximum bore diameter | *** higher speeds on request

LP3

With conical clamping ring

350 – 5,200 Nm



Features

- High torsional stiffness
- Customer specified length on request
- Good for reversing loads

Material

- **Disc pack:** highly elastic spring steel
- **Hubs and spacer:** high strength steel

Design

Two precision machined coupling hubs with conical clamping ring and spacer mounted to the disc packs by means of high strength screws and bushings for alignment and frictional clamping of the assembly. From series 25,000 assembly screws/superbolts must be used.

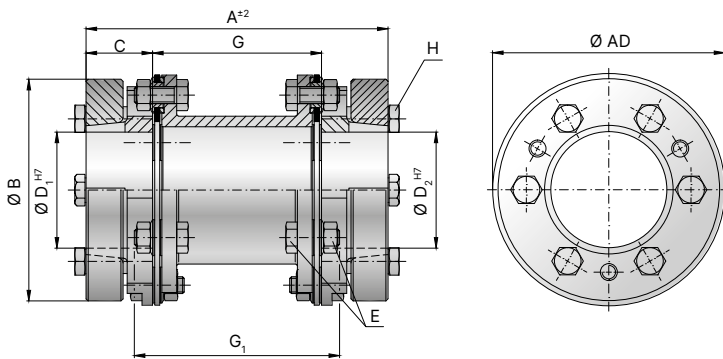

Model LP3 | Size 300–2,600

Size			300	500	700	1,100	1,600	2,600
Rated torque	(Nm)	T_{KN}	350	500	700	1,100	1,600	2,600
Maximum torque	(Nm)	T_{KNmax}	700	1,000	1,400	2,200	3,200	5,200
Overall length	(mm)	A	151	151	182	188	248	261
Outside diameter	(mm)	$\varnothing AD$	99	109	128	133	150	168
Hub diameter	(mm)	$\varnothing B$	95	105	122	130	146	165
Hub fit length	(mm)	C	35.5	35.5	43.5	46	56	63.5
Bore diameter available from \varnothing to $\varnothing H7$	(mm)	$D_{1/2}$	24 - 50	24 - 55	30 - 65	30 - 65	35 - 70	35 - 85
Assembly screw Tensioning nut	(ISO 4017) (DIN 4032)	E	M8	M8	M10	M10	M12	M12
Tightening torque	(Nm)		35	40	65	95	150	165
Distance between hubs	(mm)	G	80	80	95	96	136	134
Assembly length	(mm)	G_1	100	100	123	124	166	162
Clamping screw	(ISO 4017)	H	6 x M8	6 x M8	6 x M10	6 x M10	6 x M12	6 x M12
Tightening torque	(Nm)		20	26	39	61	98	140
Moment of inertia*	($10^{-3}kgm^2$)	$J_{ges.}$	5	7.5	16	20	40	74
Weight*	(kg)		3.6	5	7.0	8.1	13.2	18.3
Torsional stiffness disc packs	(kNm/rad)	C_T	100	140	235	270	400	600
Axial \pm	(mm)		1	1	1.5	1.5	2	2
Lateral \pm	(mm)	max. values	0.8	0.8	1	1	1.4	1.4
Angular \pm	(degree)		1.4	1.4	1.4	1.4	1.4	1.4
Max. speed	(min ⁻¹)		5,800	5,200	4,500	4,300	3,850	3,500
Max. speed (balanced)**	(min ⁻¹)		13,500	12,300	10,500	10,000	8,950	8,000

* at maximum bore diameter | ** higher speeds on request

LP3

With conical clamping ring

4,000 – 50,000 Nm



Features

- High torsional stiffness
- Customer specified length on request
- Good for reversing loads

Material

- **Disc pack:** highly elastic spring steel
- **Hubs and spacer:** high strength steel

Design

Two precision machined coupling hubs with conical clamping ring and spacer mounted to the disc packs by means of high strength screws and bushings for alignment and frictional clamping of the assembly. From series 25,000 assembly screws/superbolts must be used.

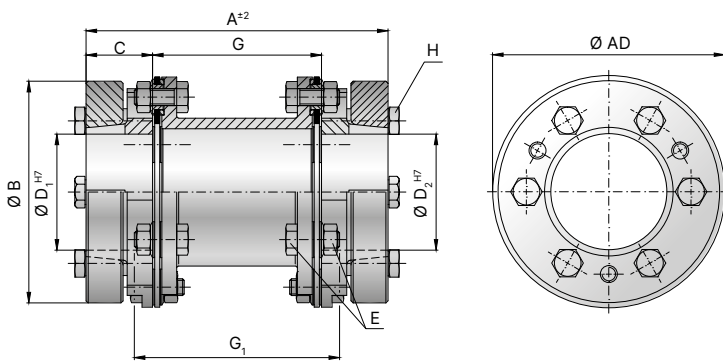

Model LP3 | Size 4,000–25,000

Size			4,000	6,000	8,000	15,000	25,000
Rated torque	(Nm)	T_{KN}	4,000	6,000	8,000	15,000	25,000
Maximum torque	(Nm)	T_{KNmax}	8,000	12,000	16,000	30,000	50,000
Overall length	(mm)	A	288	321	382	448	587.4
Outside diameter	(mm)	Ø AD	198	212	238	272	300
Hub diameter	(mm)	Ø B	184	205	230	269	295
Hub fit length	(mm)	C	74	80.5	105	112	124
Bore diameter available from Ø to Ø H7	(mm)	$D_{1/2}$	50 - 100	50 - 110	60 - 115	70 - 150	90 - 170
Assembly screw Tensioning nut	(ISO 4017) (DIN 4032)	E	M16	M16	M20	M20	M24
Tightening torque	(Nm)		360	400	755	770	47
Distance between hubs	(mm)	G	140	160	172	224	339.4
Assembly length	(mm)	G_1	174	194	220	274.6	431.6
Clamping screw	(ISO 4017)		6 x M16	6 x M16	6 x M20	6 x M20	6 x M20
Tightening torque	(Nm)	H	225	308	490	620	620
Moment of inertia*	($10^{-3}kgm^2$)	$J_{ges.}$	141	216	470	903	1,465
Weight*	(kg)		26.7	33.7	60	80	110.8
Torsional stiffness disc packs	(kNm/rad)	C_T	1,000	1,250	1,800	3,850	8,000
Axial ±	(mm)	max. values	2.5	2.5	2.5	3	4
Lateral ±	(mm)		1.4	1.5	1.6	2.2	2.6
Angular ±	(degree)		1.4	1.4	1.4	1.4	1.4
Max. speed	(min ⁻¹)		2,900	2,700	2,400	2,100	1,900
Max. speed (balanced)**	(min ⁻¹)		6,700	6,300	5,600	4,900	4,500

* at maximum bore diameter | ** higher speeds on request

LP5 S

With clamping hub single flex

350 – 30,000 Nm



Features

- Easy installation
- Keyway optional
- Compensates for axial and angular misalignment only

Material

- **Disc pack:** highly elastic spring steel
- **Hubs:** high strength steel

Design

Two precision machined split clamping hubs mounted to the disc pack by means of high strength screws and bushings for alignment and frictional clamping of the assembly.

S = single flex design

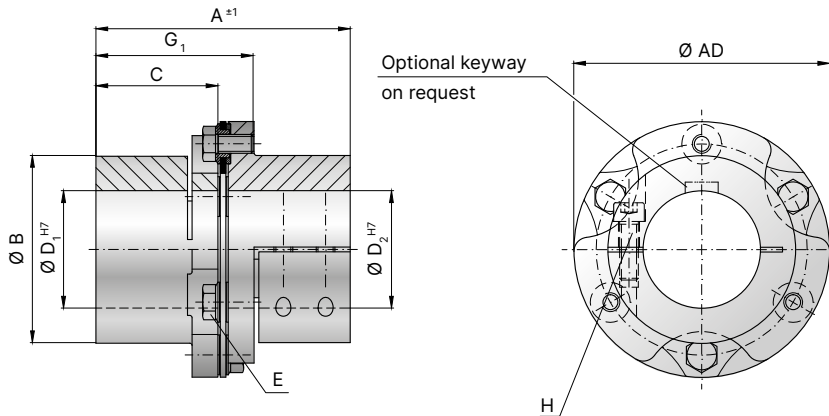

Model LP5 S | Size 300 – 15,000

Size			300	500	700	1,100	1,600	2,600	4,000	6,000	8,000	15,000
Rated torque	(Nm)	T_{KN}	350	500	700	1,100	1,600	2,600	4,000	6,000	8,000	15,000
Maximum torque	(Nm)	T_{KNmax}	700	1,000	1,400	2,200	3,200	5,200	8,000	12,000	16,000	30,000
Overall length	(mm)	A	95	113	134	151	178	189	217	237	268	324.7
Outside diameter	(mm)	$\varnothing AD$	99	109	128	133	150	168	198	212	238	272
Hub diameter	(mm)	$\varnothing B$	72	80	89	95	103	122	137	151	168	182
Hub fit length	(mm)	C	45	54	64	72	85	90	102	112	126	155
Bore diameter available from \varnothing to $\varnothing H7$	(mm)	$D_{1/2}$	18 - 48	23 - 50	25 - 58	25 - 60	28 - 64	31 - 75	38 - 90	39 - 95	50 - 102	70 - 120
Assembly screw Tensioning nut	(ISO 4017) (DIN 4032)	E	M8	M8	M10	M10	M12	M12	M16	M16	M20	M20
Tightening torque	(Nm)		35	40	65	95	150	165	360	400	755	770
Distance between hubs	(mm)	G	-	-	-	-	-	-	-	-	-	-
Assembly length	(mm)	G_1	63	72	84	96.8	114.2	119	142.1	152.1	176	205.4
Clamping screw	(ISO 4017)	H	4 x M6	4 x M8	4 x M8	4 x M10	4 x M12	4 x M14	4 x M14	4 x M16	4 x M20	4 x M18
Tightening torque	(Nm)		18	34	39	73	120	192	246	395	615	500
Moment of inertia*	($10^{-3}kgm^2$)	$J_{ges.}$	2	4	8	11	20	38	75	110	208	392
Weight*	(kg)		1.9	3	4.8	5.5	8.4	12.0	17.3	22.5	34.1	49.3
Torsional stiffness disc packs	(kNm/rad)	C_T	200	280	470	540	800	1,200	2,000	2,500	3,600	7,700
Axial \pm	(mm)		0.5	0.6	0.7	0.8	1.0	1.1	1.3	1.3	1.3	1.5
Lateral \pm	(mm)	max. values	-	-	-	-	-	-	-	-	-	-
Angular \pm	(degree)		0.7	0.7	0.7	0.7	0.7	0.7	0.7	0.7	0.7	0.7
Max. speed	(min^{-1})		5,800	5,200	4,500	4,300	3,850	3,500	2,900	2,700	2,400	2,100
Max. speed (balanced)**	(min^{-1})		13,500	12,300	10,500	10,000	8,950	8,000	6,700	6,300	5,600	4,900

* at maximum bore diameter | ** higher speeds on request

LP5 D

With clamping hub dual flex

350 – 30,000 Nm



Features

- Easy installation
- Keyway optional
- Compensates for axial, angular and lateral misalignment

Material

- **Disc pack:** highly elastic spring steel
- **Hubs and spacer:** high strength steel

Design

Two precision machined split clamping hubs and spacer plate mounted to the disc packs by means of high strength screws and bushings for alignment and frictional clamping of the assembly.

D = dual flex design

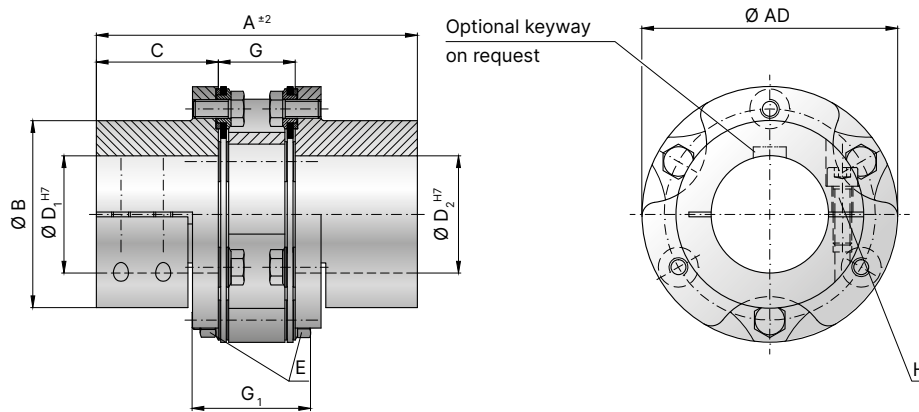

Model LP5 D | Size 300 – 15,000

Size			300	500	700	1,100	1,600	2,600	4,000	6,000	8,000	15,000
Rated torque	(Nm)	T_{KN}	350	500	700	1,100	1,600	2,600	4,000	6,000	8,000	15,000
Maximum torque	(Nm)	T_{KNmax}	700	1,000	1,400	2,200	3,200	5,200	8,000	12,000	16,000	30,000
Overall length	(mm)	A	123	141	172	192	224	236	274	302	349	396.4
Outside diameter	(mm)	$\varnothing AD$	99	109	128	133	150	168	198	212	238	272
Hub diameter	(mm)	$\varnothing B$	72	80	89	95	103	122	137	151	168	182
Hub fit length	(mm)	C	45	54	64	72	85	90	102	112	126	155
Bore diameter available from \varnothing to $\varnothing H7$	(mm)	$D_{1/2}$	18 - 48	23 - 50	25 - 58	25 - 60	28 - 64	31 - 75	38 - 90	39 - 95	50 - 102	70 - 120
Assembly screw Tensioning nut	(ISO 4017) (DIN 4032)	E	M8	M8	M10	M10	M12	M12	M16	M16	M20	M20
Tightening torque	(Nm)		35	40	65	95	150	165	360	400	755	770
Distance between hubs	(mm)	G	33	33	44	48	54	56	70	78	97	86.4
Assembly length	(mm)	G_1	50.3	50.3	61.4	66.4	77.5	77.5	100	110	132.5	132.5
Clamping screw	(ISO 4017)	H	4 x M6	4 x M8	4 x M8	4 x M10	4 x M12	4 x M14	4 x M14	4 x M16	4 x M20	4 x M18
Tightening torque	(Nm)		18	34	39	73	120	192	246	395	615	500
Moment of inertia*	(10^{-3}kgm^2)	$J_{ges.}$	3	5	11	15	27	50	103	149	291	530
Weight*	(kg)		2.7	3.9	6	7.4	10.8	15.1	22.5	29	44.8	62.8
Torsional stiffness disc packs	(kNm/rad)	C_T	100	140	235	270	400	600	1,000	1,250	1,800	3,850
Axial \pm	(mm)	max. values	1.0	1.0	1.5	1.5	2.0	2.0	2.5	2.5	2.5	3.0
Lateral \pm	(mm)		0.2	0.2	0.3	0.3	0.4	0.4	0.5	0.5	0.6	0.7
Angular \pm	(degree)		1.4	1.4	1.4	1.4	1.4	1.4	1.4	1.4	1.4	1.4
Max. speed	(min^{-1})		5,800	5,200	4,500	4,300	3,850	3,500	2,900	2,700	2,400	2,100
Max. speed (balanced)**	(min^{-1})		13,500	12,300	10,500	10,000	8,950	8,000	6,700	6,300	5,600	4,900

* at maximum bore diameter | ** higher speeds on request

LPH

With fully split clamping hub

350 – 5,200 Nm



Features

- Lateral mounting between shafts
- Easy installation and removal
- Dual flex design

Material

- **Disc pack:** highly elastic spring steel
- **Hubs and spacer:** high strength steel

Design

Two precision machined fully split clamping hubs and spacer plate mounted to the disc pack by means of high strength screws and bushings for alignment and frictional clamping of the assembly. From series 25,000 assembly screws/superbolts must be used.

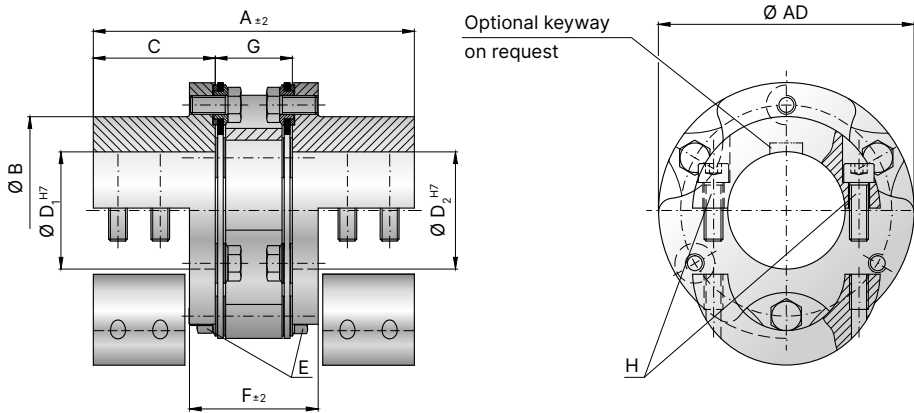

Model LPH | Size 300–2,600

Size			300	500	700	1,100	1,600	2,600
Rated torque	(Nm)	T_{KN}	350	500	700	1,100	1,600	2,600
Maximum torque	(Nm)	T_{KNmax}	700	1,000	1,400	2,200	3,200	5,200
Overall length	(mm)	A	123	141	172	192	224	236
Outside diameter	(mm)	$\varnothing AD$	99	109	128	133	150	168
Hub diameter	(mm)	$\varnothing B$	72	80	89	95	100	116.5
Hub fit length	(mm)	C	45	54	64	72	85	90
Bore diameter available from \varnothing to $\varnothing H7$	(mm)	$D_{1/2}$	18 - 48	23 - 50	25 - 58	25 - 60	28 - 64	31 - 75
Assembly screw (ISO 4017) Tensioning nut (DIN 4032)		E	M8	M8	M10	M10	M12	M12
Tightening torque	(Nm)		35	40	65	95	150	165
Distanz	(mm)	F	62	66	74	80	96	98
Distance between hubs	(mm)	G	33	33	44	48	54	56
Clamping screw (ISO 4017)		H	8 x M6	8 x M8	8 x M8	8 x M10	8 x M10	8 x M12
Tightening torque	(Nm)		16	28	34	63	86	143
Moment of inertia*	($10^{-3}kgm^2$)	$J_{ges.}$	3	5	11	15	26	46
Weight*	(kg)		2.7	3.9	5.9	7.4	10.3	14
Torsional stiffness disc packs	(kNm/rad)	C_T	100	140	235	270	400	600
Axial \pm	(mm)	max. values	1.0	1.0	1.5	1.5	2.0	2.0
Lateral \pm	(mm)		0.2	0.2	0.3	0.3	0.4	0.4
Angular \pm	(degree)		1.4	1.4	1.4	1.4	1.4	1.4
Max. speed	(min^{-1})		5,800	5,200	4,500	4,300	3,850	3,500
Max. speed (balanced)**	(min^{-1})		13,500	12,300	10,500	10,000	8,950	8,000

* at maximum bore diameter | ** higher speeds on request

LPH

With fully split clamping hub

4,000 – 50,000 Nm



Features

- Lateral mounting between shafts
- Easy installation and removal
- Dual flex design

Material

- **Disc pack:** highly elastic spring steel
- **Hubs and spacer:** high strength steel

Design

Two precision machined fully split clamping hubs and spacer plate mounted to the disc pack by means of high strength screws and bushings for alignment and frictional clamping of the assembly. From series 25,000 assembly screws/superbolts must be used.

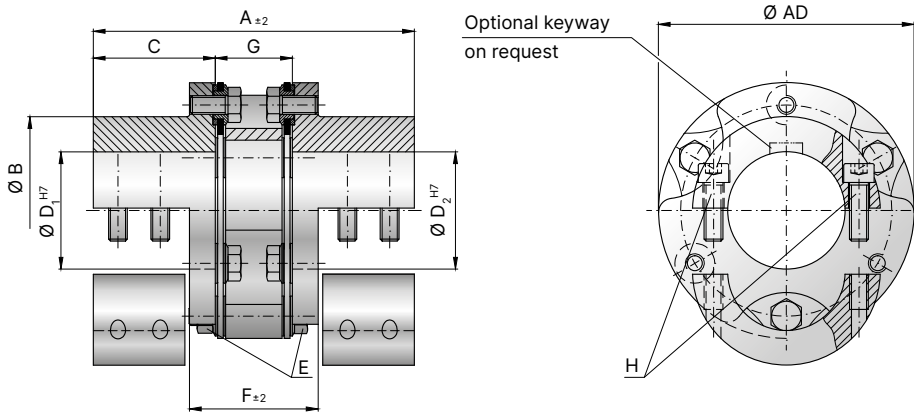

Model LPH | Size 4,000–25,000

Size			4,000	6,000	8,000	15,000	25,000
Rated torque	(Nm)	T_{KN}	4,000	6,000	8,000	15,000	25,000
Maximum torque	(Nm)	T_{KNmax}	8,000	12,000	16,000	30,000	50,000
Overall length	(mm)	A	274	302	349	396.4	468.4
Outside diameter	(mm)	$\varnothing AD$	198	212	238	272	300
Hub diameter	(mm)	$\varnothing B$	137	149	168	182	189
Hub fit length	(mm)	C	102	112	126	155	165
Bore diameter available from \varnothing to $\varnothing H7$	(mm)	$D_{1/2}$	38 - 90	39 - 95	50 - 102	70 - 120	90 - 135
Assembly screw Tensioning nut	(ISO 4017) (DIN 4032)	E	M16	M16	M20	M20	M24
Tightening torque	(Nm)		360	400	755	770	47
Distanz	(mm)	F	124	132	163	166.4	244.4
Distance between hubs	(mm)	G	70	78	97	86.4	138.4
Clamping screw	(ISO 4017)	H	8 x M14	8 x M16	8 x M20	8 x M18	12 x M16
Tightening torque	(Nm)		215	342	530	500	390
Moment of inertia*	($10^{-3}kgm^2$)	$J_{ges.}$	103	146	287	526	894
Weight*	(kg)		22.5	28.5	44.2	62.2	84.8
Torsional stiffness disc packs	(kNm/rad)	C_T	1,000	1,250	1,800	3,850	8,000
Axial \pm	(mm)		2.5	2.5	2.5	3.0	4.0
Llateral \pm	(mm)	max. values	0.5	0.5	0.6	0.7	0.8
Angular \pm	(degree)		1.4	1.4	1.4	1.4	1.4
Max. speed	(min^{-1})		2,900	2,700	2,400	2,100	1,900
Max. speed (balanced)**	(min^{-1})		6,700	6,300	5,600	4,900	4,500

* at maximum bore diameter | ** higher speeds on request

LPZ

Spacer plate

350 – 50,000 Nm



Features

- High torsional stiffness
- Dual flex design
- For combination of hub types

Material

- **Spacer plate:** high strength steel

Design

For use when combining various hub designs with two disc packs and spacer plate.

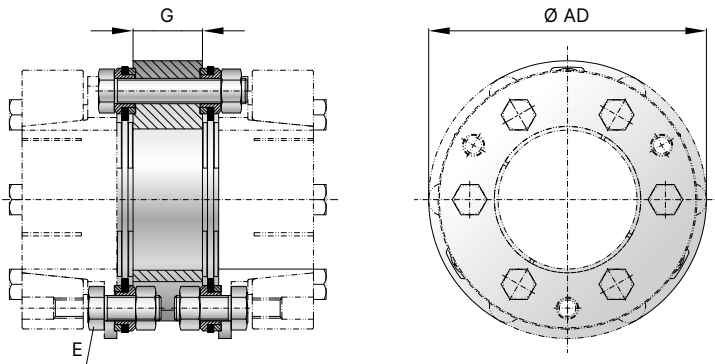

Model LPZ | Size 300–25,000

Size			300	500	700	1,100	1,600	2,600	4,000	6,000	8,000	15,000	25,000
Rated torque*	(Nm)	T_{KN}	350	500	700	1,100	1,600	2,600	4,000	6,000	8,000	15,000	25,000
Maximum torque	(Nm)	T_{KNmax}	700	1,000	1,400	2,200	3,200	5,200	8,000	12,000	16,000	30,000	50,000
Distance between hubs	(mm)	G	23	23	32	34	38	38	44	52	65	57	105
Outside diameter	(mm)	Ø AD	99	109	128	133	150	168	198	212	238	272	300
Assembly screw Tensioning nut	(ISO 4017) (DIN 4032)	E	M8	M8	M10	M10	M12	M12	M16	M16	M20	M20	M24
Tightening torque	(Nm)		35	40	65	95	150	165	360	400	755	770	47
Moment of inertia	($10^{-3}kgm^2$)	$J_{ges.}$	0.6	1	2.5	3	5	9	18	28	57	93	271
Weight	(kg)		0.53	0.66	1.1	1.4	1.8	2.3	3.7	5	7.8	9.7	24.2
Axial ±	(mm)		1	1	1.5	1.5	2	2	2.5	2.5	2.5	3	4
Lateral ±	(mm)	max. values	0.2	0.2	0.3	0.3	0.4	0.4	0.5	0.5	0.6	0.7	0.8
Angular ±	(degree)		1.4	1.4	1.4	1.4	1.4	1.4	1.4	1.4	1.4	1.4	1.4
Max. speed	(min^{-1})		5,800	5,200	4,500	4,300	3,850	3,500	2,900	2,700	2,400	2,100	1,900
Max. speed (balanced)*	(min^{-1})		13,500	12,300	10,500	10,000	8,950	8,000	6,700	6,300	5,600	4,900	4,500

* higher speeds on request



With conical clampin ring hub and flange mounting for connection to torque transducers

- High torsional stiffness
- High clamping pressure
- Zero backlash torque transmission



With integral coolant delivery pipe

- Spacer: carbon fiber, aluminum or steel
- For high speeds
- Customer specified length available
- Dual flex design

